

# Flexible Couplings N-EUPEX Series

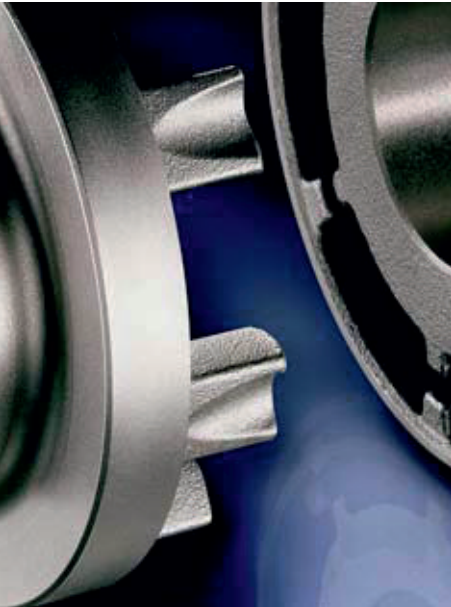

7/2	<a href="#">Overview</a>
7/3	<a href="#">Benefits</a>
7/3	<a href="#">Application</a>
7/3	<a href="#">Function</a>
7/4	<a href="#">Design</a>
7/7	<a href="#">Technical data</a>
7/10	<b>Type A for easy elastomer flexible replacement</b>
7/10	<a href="#">Selection and ordering data</a>
7/11	<b>Type B</b>
7/11	<a href="#">Selection and ordering data</a>
7/12	<b>Type H</b>
7/12	<a href="#">Selection and ordering data</a>
7/14	<b>Type D for easy elastomer flexible replacement</b>
7/14	<a href="#">Selection and ordering data</a>
7/16	<b>Type E</b>
7/16	<a href="#">Selection and ordering data</a>
7/17	<b>Type P with brake drum for easy elastomer flexible replacement</b>
7/17	<a href="#">Selection and ordering data</a>
7/18	<b>Type O with brake drum</b>
7/18	<a href="#">Selection and ordering data</a>
7/19	<b>Type DBDR with brake disk for easy elastomer flexible replacement</b>
7/19	<a href="#">Selection and ordering data</a>
7/20	<b>Type DBD with brake disk for easy elastomer flexible replacement</b>
7/20	<a href="#">Selection and ordering data</a>
7/21	<b>Type EBD with brake disk</b>
7/21	<a href="#">Selection and ordering data</a>
7/22	<b>Type ADS for easy elastomer flexible replacement</b>
7/22	<a href="#">Selection and ordering data</a>
7/23	<b>Type BDS</b>
7/23	<a href="#">Selection and ordering data</a>
7/24	<b>Type HDS</b>
7/24	<a href="#">Selection and ordering data</a>
7/26	<b>Spare and wear parts</b>
7/26	<a href="#">Selection and ordering data</a>

# FLENDER Standard Couplings

## Flexible Couplings - N-EUPEX and N-EUPEX DS Series

### General information

#### Overview

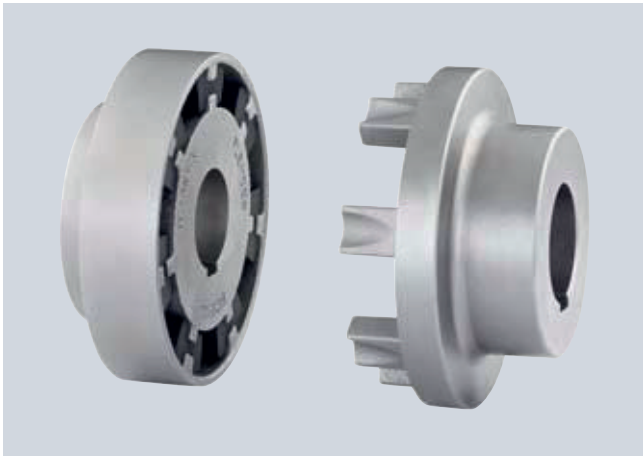

N-EUPEX as overload-holding, fail-safe series

N-EUPEX and N-EUPEX DS claw couplings connect machines. They compensate for shaft misalignment, generating only low restorative forces.

The torque is conducted through elastomer flexibles, so the coupling has typically flexible rubber properties.

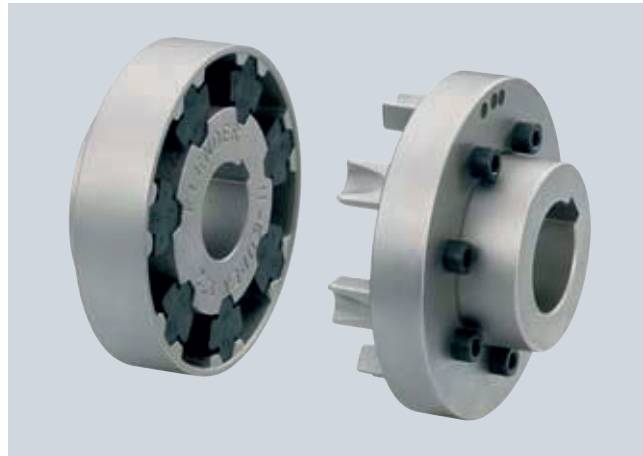

N-EUPEX DS as overload-shedding, non-fail-safe series

N-EUPEX couplings are overload-holding. By contrast, the N-EUPEX DS series is designed so that overload or advanced wear causes irreparable damage to the elastomer flexibles. The metal parts of N-EUPEX DS couplings can then rotate freely against one another without contact.

7

#### Elastomer flexible of the N-EUPEX series



The flexibles of the N-EUPEX coupling are subjected to compression. If the flexibles are irreparably damaged, the hub parts come into contact with metal. This "emergency operation capability" is required, e.g., in the case of fire pump drives.

#### Elastomer flexible of the N-EUPEX DS series

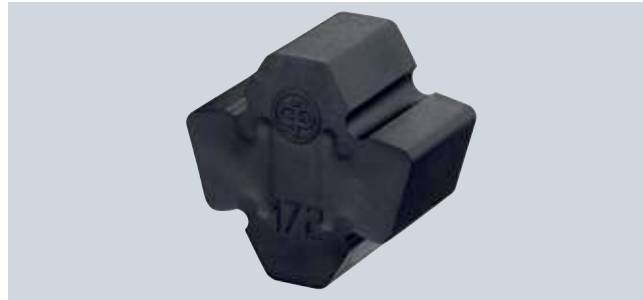

The flexibles of the N-EUPEX DS series are subjected to compression and bending forces. If the flexibles are irreparably damaged, the metal parts turn against one another without contact, and the power transmission is separated. Fitting new flexibles will make the coupling once more usable. The capacity of the N-EUPEX DS series to shed overloads is especially in demand for highly sensitive machines.

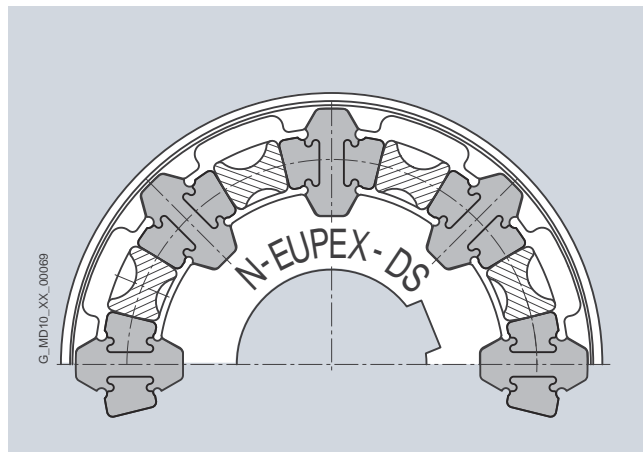
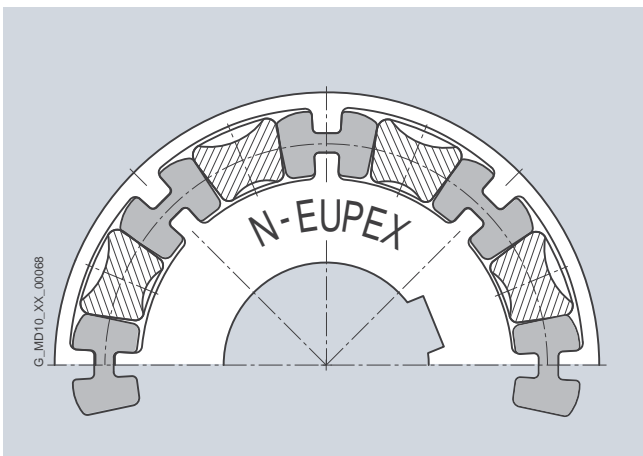

# FLENDER Standard Couplings

## Flexible Couplings - N-EUPEX and N-EUPEX DS Series

### General information

#### Benefits

N-EUPEX couplings are designed on the modular principle and have a very simple construction. N-EUPEX types are made up of subassemblies to suit requirements. The couplings are assembled by simply fitting the coupling halves together. Wear is restricted to the elastomer flexibles, which must be replaced at the end of their service life.

Depending on type, the elastomer flexibles can be changed without moving the coupled machines.

The coupling parts are readily available from stock and are mostly finish-machined, i.e. with finished bore, keyway, set screw and balancing.

#### Optionally:

The wear indicator for N-EUPEX couplings enables the condition of the flexible to be easily assessed. The wear condition can also be ascertained with the aid of a stroboscope while the coupling is rotating. The production process can thus continue undisturbed.

If the stroboscope is to be used in a potentially explosive environment, you can enquire about the equipment for this at FLENDER.

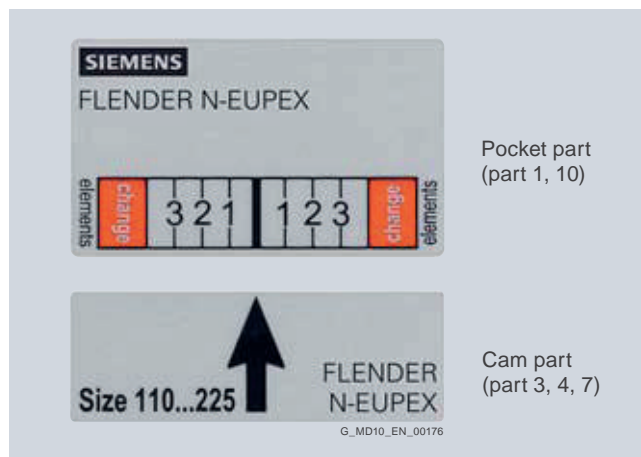

The wear indicator must be attached to the outside diameter of the coupling after the coupling has been fitted.

#### Application

The N-EUPEX coupling is available as a catalog standard in 23 sizes with a rated torque of between 19 Nm and 62000 Nm. The coupling is suitable for use at ambient temperatures of between  $-30\text{ °C}$  and  $+80\text{ °C}$ . By using alternative elastomer buffers, the permissible ambient temperature range can be extended to between  $-50\text{ °C}$  and  $+100\text{ °C}$ .

Frequently, the coupling is used to connect the motor to the gear unit input shaft. The coupling is suitable especially for drives with uniform to average dynamic loads. Examples of applications are pump drives, ventilator drives or crane running gear. Furthermore, N-EUPEX couplings can be used as add-on couplings, particularly on FLUDEX fluid couplings or ARPEX AKR safety couplings. In the case of drives with a diesel engine, N-EUPEX couplings are suitable for driven machines with a low mass moment of inertia.

In the case of diesel engine drives, the actual dynamic coupling load should be checked by measurement or torsional vibration calculations.



**Coupling suitable for potentially explosive environments. Complies with Directive 94/9/EC for:**

CE Ex II 2 G T4 / T5 / T6 D120 °C  
 $-30\text{ °C} \leq T_a \leq +80\text{ °C} / +50\text{ °C} / +40\text{ °C}$

CE Ex I M2

#### Function

The motor torque is transmitted to the hub at the drive end via the shaft-hub connection, which is mostly designed as a keyway connection. The torque is transmitted to the hub on the output side with the aid of elastomer flexibles. The hub on the output side further transmits the torque to the driven machine or a gear unit placed in between. Because of the primarily compression-loaded elastomer flexibles, the coupling has a progressive torsional stiffness.

In the case of the N-EUPEX DS coupling series, the elastomer flexible is subjected to bending and compression loads. In the event of overload or advanced wear, the coupling disconnects positively and the flexibles are irreparably damaged. The metal parts then rotate without touching one another. After new elastomer flexibles are fitted, the N-EUPEX DS coupling is once more operable.

N-EUPEX DS couplings are maintenance-free, even in potentially explosive environments, so long as the possible torque interruption does not lead to an unacceptable disruption of the production process.

# FLENDER Standard Couplings

## Flexible Couplings - N-EUPEX and N-EUPEX DS Series

### General information

#### Design

N-EUPEX and N-EUPEX DS couplings consist of two hub parts mounted on the machine shafts. The coupling parts are connected positively by means of elastomer flexibles. On the two-part variant, the elastomer flexibles can be changed only if one

of the coupled machines is moved. On the three-part variants, the bolted cam ring can be released and moved to enable the flexible to be changed without moving the coupled machines.

#### Materials

Cam parts, pocket parts, adapters and hubs

Grey cast iron EN-GJL-250

Flexible materials

##### • N-EUPEX series

Material/description	Hardness	Identification	Ambient temperature
<b>NBR standard type</b>	<b>80 Shore A</b>	<b>Flexible black with blue stripe</b>	<b>-30 °C ... +80 °C</b>
NBR soft	65 Shore A	Flexible black with green stripe	-30 °C ... +80 °C
NBR hard	90 Shore A	Flexible black with magenta stripe	-30 °C ... +80 °C
NBR normal low-backlash	80 Shore A	Flexible black with yellow stripe	-30 °C ... +80 °C
NBR soft low-backlash	65 Shore A	Flexible black with white stripe	-30 °C ... +80 °C
NR for low temperature	80 Shore A	Flexible black with orange stripe	-50 °C ... +50 °C
HNBR high temperature	80 Shore A	Flexible black with red stripe	-10 °C ... +100 °C

##### • N-EUPEX DS series

Material/description	Hardness	Identification	Ambient temperature
<b>NBR compound flexibles for sizes 66 ... 272</b>	<b>80/90 Shore A 2 components</b>	<b>Flexible black</b>	<b>-30 °C ... +80 °C</b>
<b>NBR hard for sizes 305 ... 556</b>	<b>90 Shore A</b>	<b>Flexible black</b>	<b>-30 °C ... +80 °C</b>
PU electrically insulating	95 Shore A	Flexible blue	-30 °C ... +50 °C

PU elastomer flexibles in special design on request.

The technical data and product codes do not include the flexible variants NBR low-backlash, HNBR high temperature and NR low temperature and the DS flexibles polyurethane electrically insulating.

Technical data, prices and product codes on request.

Brake disks

EN-GJS-400 spheroidal graphite cast iron or S355J2G3 steel

Brake drums

Grey cast iron EN-GJL-250

Low-temperature application

Shock loads in the drive caused by e.g. starting of drives with large masses to be accelerated (e.g. in fan drives) result in high component loads, particularly at low temperatures. For such applications a particularly robust coupling series must be selected. Of the flexible couplings, the RUPEX pin-and-bush coupling is especially suited for this.

#### Types of N-EUPEX claw coupling

Type	Description
A	Fail-safe, 3-part
B	Fail-safe, 2-part
D	Fail-safe, 3-part, flange variant
E	Fail-safe, 2-part, flange variant
H	Fail-safe, with adapter
O	Fail-safe, 2-part, with brake drum
P	Fail-safe, 3-part, with brake drum
EBD	Fail-safe, 2-part, with brake disk
DBD	Fail-safe, 3-part, with brake disk
DBDR	Fail-safe, 3-part, with brake disk, brake disk radially dismountable
ADS	Non-fail-safe, 3-part
BDS	Non-fail-safe, 2-part
HDS	Non-fail-safe, with adapter

Further application-related coupling types are available. Dimension sheets for and information on these are available on request.

#### Types of N-EUPEX claw coupling on request

Type	Description
AT	Fail-safe, 3-part, with Taper clamping bush
BT	Fail-safe, 2-part, with Taper clamping bush
G	Fail-safe, 2-part, with intermediate shaft
F	Fail-safe, 3-part, with intermediate shaft
K	Fail-safe, 3-part, with brake drum to customer's requirement
L	Fail-safe, 2-part, with brake drum to customer's requirement
M	Fail-safe, 2-part, with flange dimensions to SAE J620d

# FLENDER Standard Couplings

## Flexible Couplings - N-EUPEX and N-EUPEX DS Series

### General information

#### Modular principle of N-EUPEX types

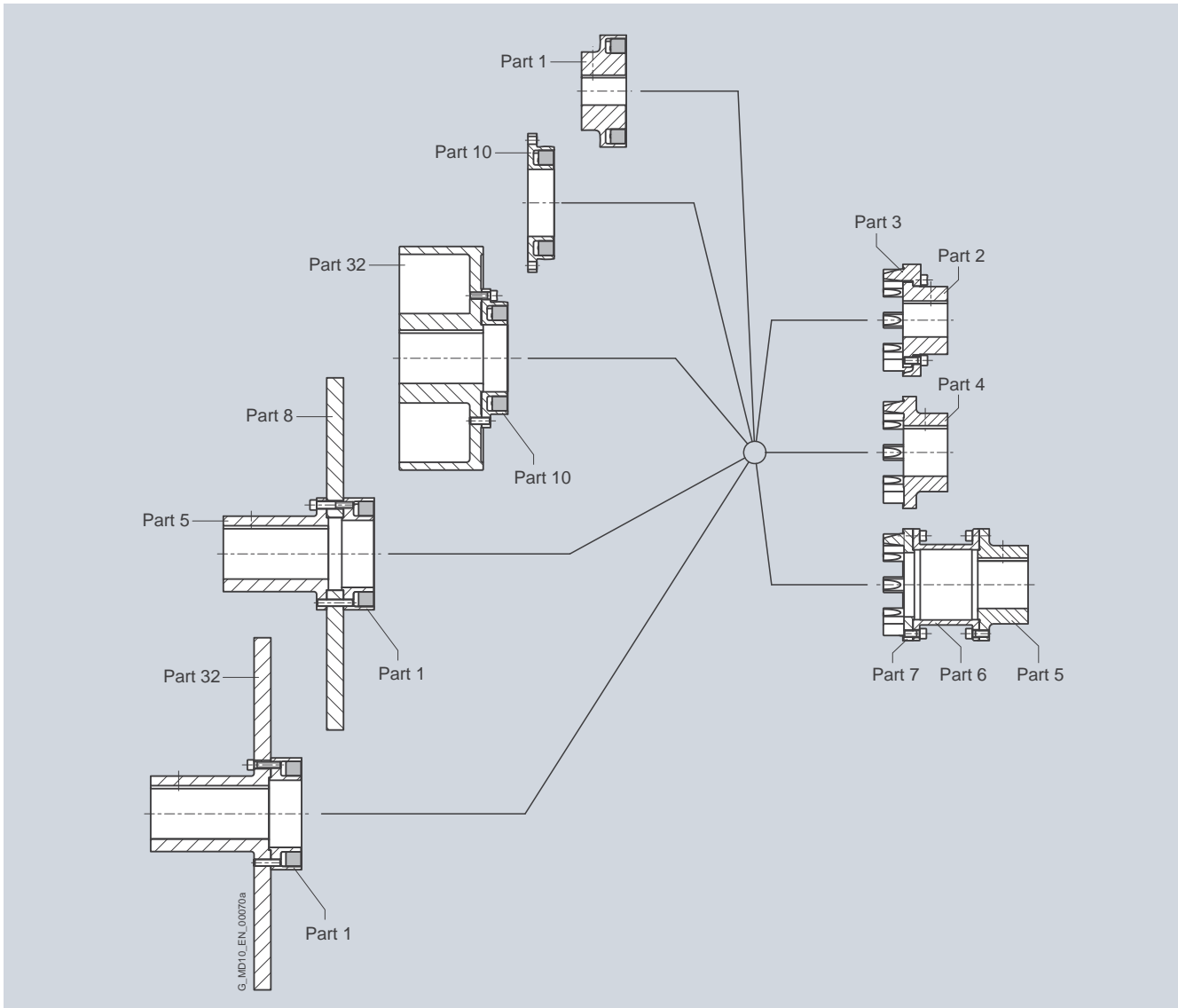

7

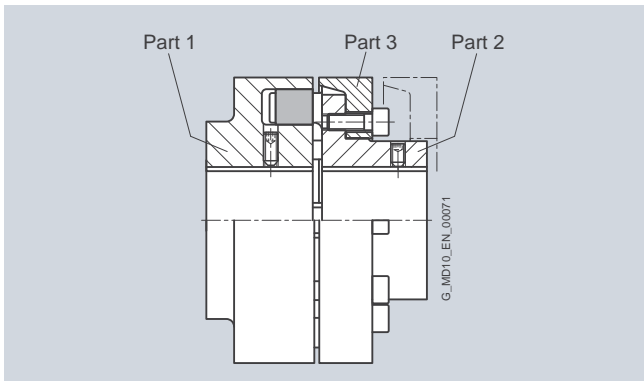

Types A and ADS

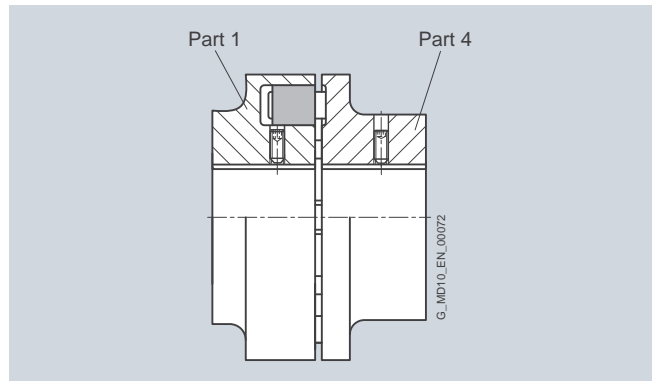

Types B and BDS

# FLENDER Standard Couplings

## Flexible Couplings - N-EUPEX and N-EUPEX DS Series

### General information

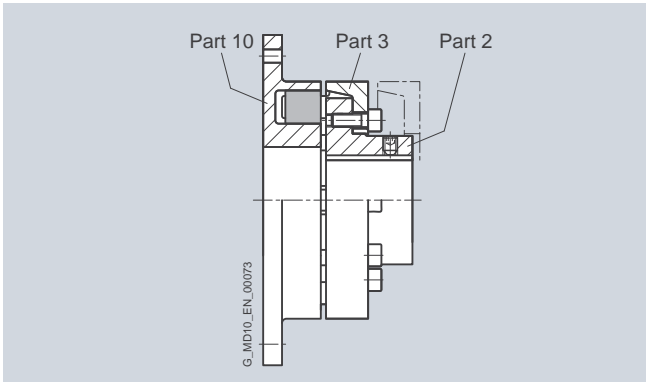

Type D

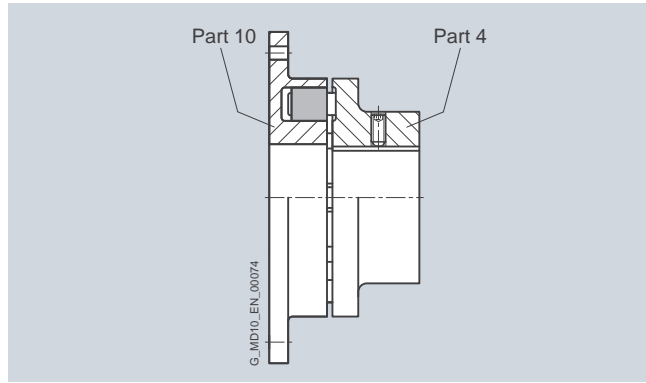

Type E

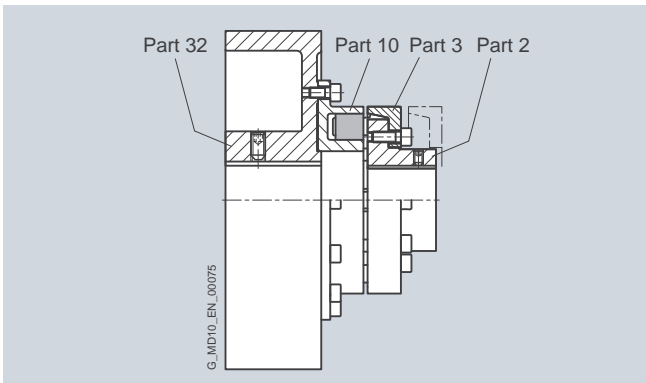

Type P

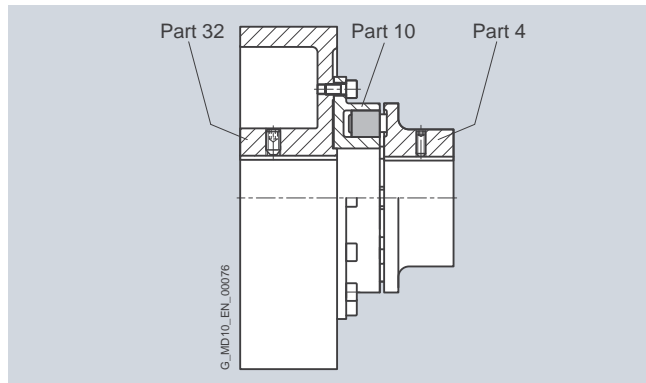

Type O

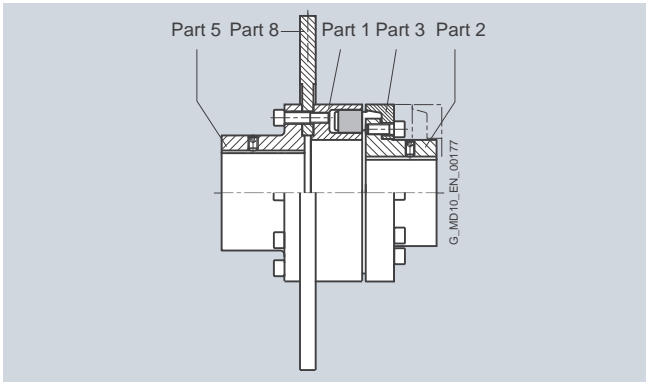

Type DBDR

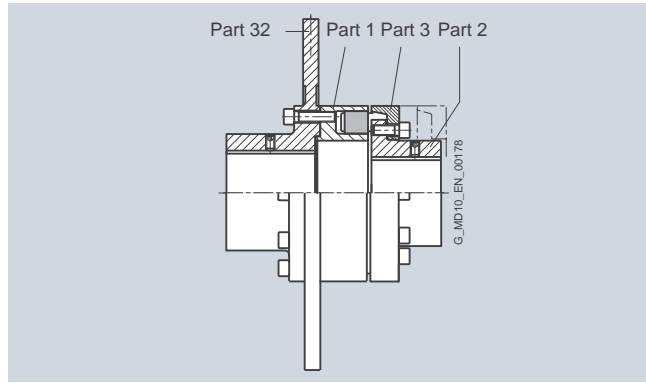

Type DBD

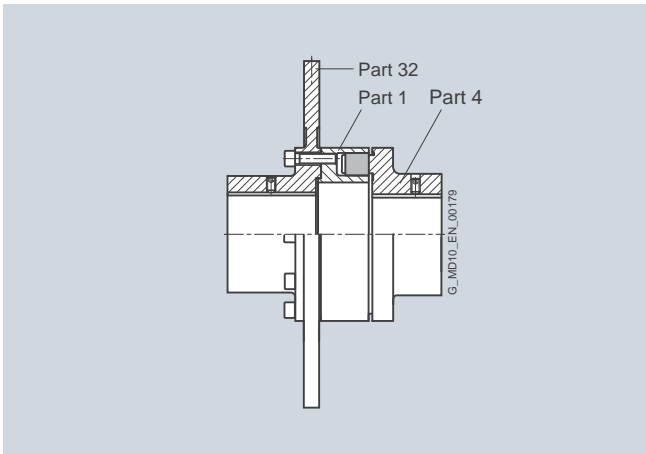

Type EBD

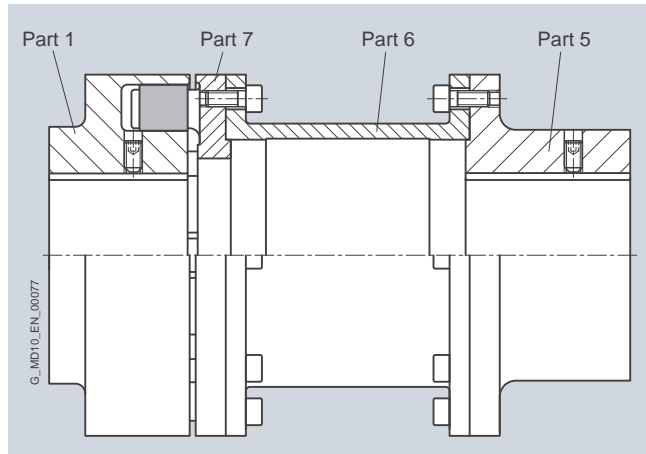

Types H and HDS

Further application-related coupling types are available. Dimension sheets for and information on these are available on request.

# FLENDER Standard Couplings

## Flexible Couplings - N-EUPEX and N-EUPEX DS Series

### General information

#### Technical data

##### Power ratings of the N-EUPEX series

Size	Rated torque for flexible type			Torsional stiffness at 50 % capacity utilization for flexible type			Assembly Gap dimension $\Delta S$ mm	Permitted shaft misalignment at $n = 1500 \text{ rpm}$ <sup>1)</sup>		
	65 ShoreA	80 ShoreA	90 ShoreA	65 ShoreA	80 ShoreA	90 ShoreA		Axial $\Delta K_a$ mm	Radial $\Delta K_r$ mm	Angle $\Delta K_w$ °
	$T_{KN}$ Nm	$T_{KN}$ Nm	$T_{KN}$ Nm	$C_{Tdyn 50 \%}$ kNm/rad	$C_{Tdyn 50 \%}$ kNm/rad	$C_{Tdyn 50 \%}$ kNm/rad				
58	11	19	19	0.22	0.5	0.9	1.0	0.2	0.2	0.15
68	21	34	34	0.4	0.9	1.7	1.0	0.2	0.2	0.15
80	37	60	60	0.9	2.4	4.2	1.0	0.2	0.2	0.12
95	63	100	100	1.5	4	7	1.0	0.2	0.2	0.12
110	100	160	160	2.5	6	11	1.0	0.2	0.2	0.10
125	150	240	240	3.5	9	16	1.0	0.25	0.25	0.10
140	230	360	360	5.5	14	23	1.0	0.25	0.25	0.10
160	350	560	560	11	28	48	2.0	0.3	0.3	0.10
180	550	880	880	18	48	83	2.0	0.3	0.3	0.10
200	850	1340	1340	30	80	130	2.0	0.3	0.3	0.09
225	1260	2000	2000	50	125	200	2.0	0.35	0.35	0.09
250	1760	2800	2800	65	170	290	2.5	0.35	0.35	0.08
280	2460	3900	3900	95	250	400	2.5	0.4	0.4	0.08
315	3500	5500	5500	160	410	660	2.5	0.4	0.4	0.08
350	4850	7700	7700	230	590	940	2.5	0.5	0.5	0.08
400	6500	10300	10300	330	860	1400	2.5	0.5	0.5	0.08
440	8500	13500	13500	470	1200	2000	2.5	0.6	0.6	0.08
480	10500	16600	16600	560	1500	2300	2.5	0.6	0.6	0.07
520	13300	21200	21200	660	1700	2750	2.5	0.65	0.65	0.07
560	18300	29000	29000	1200	3100	4200	3.0	0.65	0.65	0.07
610	24000	38000	38000	1600	4200	5500	3.0	0.75	0.75	0.07
660	30900	49000	49000	2000	5100	6700	3.0	0.8	0.8	0.07
710	39000	62000	62000	2600	6700	8700	3.0	0.9	0.9	0.07

For maximum coupling torque:

$$T_{Kmax} = 3.0 \cdot T_{KN}$$

For coupling overload torque:

$$T_{KOL} = 3.5 \cdot T_{KN}$$

For coupling fatigue torque:  $T_{KW} = 0.15 \cdot T_{KN}$ , where  $T_N > T_W$  must be adhered to.

##### Torsional stiffness and damping

The values stated in the above table apply to a capacity utilization of 50 %, an excitation amplitude of 10 %  $T_{KN}$  with the frequency 10 Hz and an ambient temperature of 20 °C. Dynamic torsional stiffness is dependent on load and increases in proportion to capacity utilization. The following table shows the correction factors for different nominal loads.

$$C_{Tdyn} = C_{Tdyn 50 \%} \cdot FKC$$

	Capacity utilization $T_N / T_{KN}$						
	20 %	40 %	50 %	60 %	70 %	80 %	100 %
<b>Sizes 58 ... 520</b>							
Correction factor FKC 65/80 ShoreA	0.5	0.8	1	1.2	1.3	1.6	2.0
Correction factor FKC 90 ShoreA	0.7	0.9	1	1.1	1.2	1.3	1.5
<b>Sizes 560 ... 710</b>							
Correction factor FKC 65/80 ShoreA	0.4	0.8	1	1.2	1.4	1.6	2.2
Correction factor FKC 90 ShoreA	0.5	0.8	1	1.2	1.3	1.5	1.9

##### The damping coefficient is $\Psi = 1.4$

Furthermore, torsional stiffness and damping depend on the ambient temperature and the frequency and amplitude of the torsional vibration excitation. More precise torsional stiffness and damping parameters on request.

<sup>1)</sup> The maximum speed of the respective type must be noted. For further information on permissible shaft misalignment, please see the operating instructions.

##### Permitted shaft misalignment

The permitted shaft misalignment depends on the operating speed. As the speed increases, lower shaft misalignment values are permitted. The following table shows the correction factors for different speeds.

The maximum speed for the respective coupling size must be observed!

$$\Delta K_{perm} = \Delta K_{1500} \cdot FKV$$

	Speed in rpm			
	500	1000	1500	3000
Correction factor FKV	1.7	1.2	1.0	0.70

The axial misalignment may occur dynamically at frequencies up to 10 Hz. For fitting, a maximum gap dimension of  $S_{max} = S + \Delta S$  and a minimum gap dimension of  $S_{min} = S - \Delta S$  are permitted.

Shaft misalignments  $\Delta K_a$ ,  $\Delta K_r$  and  $\Delta K_w$  may occur simultaneously.

# FLENDER Standard Couplings

## Flexible Couplings - N-EUPEX and N-EUPEX DS Series

### General information

#### Power ratings of the N-EUPEX DS series

Size	Rated torque $T_{KN}$ Nm	Torsional stiffness at 50 % capacity utilization $C_{Tdyn}$ kNm/rad	Assembly Gap dimension $\Delta S$ mm	Permitted shaft misalignment at speed $n = 1500$ rpm		
				Axial $\Delta K_a$ mm	Radial $\Delta K_r$ mm	Angle $\Delta K_w$ °
66	19	0.7	1.0	0.2	0.2	0.15
76	34	1.3	1.0	0.2	0.2	0.15
88	60	2.5	1.0	0.2	0.2	0.12
103	100	3.8	1.0	0.2	0.2	0.12
118	160	6	1.0	0.2	0.2	0.10
135	240	10	1.0	0.25	0.25	0.10
152	360	13	1.0	0.25	0.25	0.10
172	560	26	2.0	0.3	0.3	0.10
194	880	45	2.0	0.3	0.3	0.10
218	1340	67	2.0	0.3	0.3	0.09
245	2000	101	2.0	0.35	0.35	0.09
272	2800	142	2.5	0.35	0.35	0.08
305	3900	204	2.5	0.4	0.4	0.08
340	5500	335	2.5	0.4	0.4	0.08
380	7700	459	2.5	0.5	0.5	0.08
430	10300	699	2.5	0.5	0.5	0.08
472	13500	941	2.5	0.6	0.6	0.08
514	16600	1209	2.5	0.6	0.6	0.07
556	21200	1474	2.5	0.65	0.65	0.07

Flexibles of sizes 66 to 272 are of the compound type with a hard core and soft thrust pieces. Sizes 305 to 556 are completely made of 90 ShoreA NBR material.

For maximum coupling torque:

$$T_{Kmax} = 2.0 \cdot T_{KN}$$

For coupling overload torque:

$$T_{KOL} = 3.0 \cdot T_{KN}$$

For coupling fatigue torque:

$$T_{KW} = 0.15 \cdot T_{KN}$$

#### Torsional stiffness and damping

The values stated in the above table apply to a capacity utilization of 50 %, an excitation amplitude of 10 %  $T_{KN}$  with the frequency 10 Hz and an ambient temperature of 20 °C. Dynamic torsional stiffness is dependent on load and increases in proportion to capacity utilization. The following table shows the correction factors for different rated loads.

$$C_{Tdyn} = C_{Tdyn 50\%} \cdot FKC$$

Correction factor FKC	Capacity utilization $T_N / T_{KN}$						
	20 %	40 %	50 %	60 %	70 %	80 %	100 %
	0.7	0.9	1	1.1	1.2	1.3	1.5

#### The damping coefficient is $\Psi = 1.4$

Torsional stiffness and damping is further dependent on the ambient temperature and the frequency and amplitude of the torsional vibration excitation. More precise torsional stiffness and damping parameters on request.

#### Permitted shaft misalignment

The permitted shaft misalignment depends on the operating speed. As the speed increases, lower shaft misalignment values are permitted. The following table shows the correction factors for different speeds.

The maximum speed for the respective coupling size must be noted!

$$\Delta K_{perm} = \Delta K_{1500} \cdot FKV$$

Correction factor FKV	Speed in rpm			
	500	1000	1500	3000
	1.6	1.20	1.0	0.70

The axial misalignment may occur dynamically at frequencies up to 10 Hz. For fitting, a maximum gap dimension of  $S_{max} = S + \Delta S$  and a minimum gap dimension of  $S_{min} = S - \Delta S$  are permitted.

Shaft misalignments  $\Delta K_a$ ,  $\Delta K_r$  and  $\Delta K_w$  may occur simultaneously.



# FLENDER Standard Couplings

## Flexible Couplings - N-EUPEX and N-EUPEX DS Series

### General information

#### Assignment of N-EUPEX sizes to IEC standard motors

The assignment applies to an application factor of 1.25.

Outputs  $P_M$  of IEC motors and assigned N-EUPEX couplings

Three-phase motor Size	Output at $\approx 3000$ rpm $P_M$ kW	N-EUPEX coupling Size	Output at $\approx 1500$ rpm $P_M$ kW	N-EUPEX coupling Size	Output at $\approx 1000$ rpm $P_M$ kW	N-EUPEX coupling Size	Output at $\approx 750$ rpm $P_M$ kW	N-EUPEX coupling Size	DE shaft end D x E to IEC	
									D mm	E mm
<b>56</b>	0.09	<b>58</b>	0.06	<b>58</b>					9	20
	0.12	<b>58</b>	0.09	<b>58</b>						
<b>63</b>	0.18	<b>58</b>	0.12	<b>58</b>					11	23
	0.25	<b>58</b>	0.18	<b>58</b>						
<b>71</b>	0.37	<b>58</b>	0.25	<b>58</b>					14	30
	0.55	<b>58</b>	0.37	<b>58</b>						
<b>80</b>	0.75	<b>58</b>	0.55	<b>58</b>	0.37	<b>58</b>			19	40
	1.1	<b>58</b>	0.75	<b>58</b>	0.55	<b>58</b>				
<b>90 S</b>	1.5	<b>68</b>	1.1	<b>68</b>	0.75	<b>68</b>			24	50
<b>90 L</b>	2.2	<b>68</b>	1.5	<b>68</b>	1.1	<b>68</b>			24	50
<b>100 L</b>	3	<b>80</b>	2.2	<b>80</b>	1.5	<b>80</b>	0.75	<b>80</b>	28	60
			3	<b>80</b>			1.1	<b>80</b>		
<b>112 M</b>	4	<b>80</b>	4	<b>80</b>	2.2	<b>80</b>	1.5	<b>80</b>	28	60
<b>132 S</b>	5.5	<b>95</b>	5.5	<b>95</b>	3	<b>95</b>	2.2	<b>95</b>	38	80
	7.5	<b>95</b>								
<b>132 M</b>			7.5	<b>95</b>	4	<b>95</b>	3	<b>95</b>	38	80
					5.5	<b>95</b>				
<b>160 M</b>	11	<b>95</b>	11	<b>95</b>	7.5	<b>95</b>	4	<b>95</b>	42	110
	15	<b>95</b>					5.5	<b>95</b>		
<b>160 L</b>	18.5	<b>95</b>	15	<b>110</b>	11	<b>110</b>	7.5	<b>110</b>	42	110
<b>180 M</b>	22	<b>110</b>	18.5	<b>110</b>					48	110
<b>180 L</b>			22	<b>125</b>	15	<b>125</b>	11	<b>125</b>	48	110
<b>200 L</b>	30	<b>125</b>	30	<b>125</b>	18.5	<b>125</b>	15	<b>125</b>	55	110
	37	<b>125</b>			22	<b>140</b>				
<b>225 S</b>			37	<b>140</b>			18.5	<b>140</b>	55	110
									60	140
<b>225 M</b>	45	<b>125</b>	45	<b>140</b>	30	<b>140</b>	22	<b>140</b>	55	110
									60	140
<b>250 M</b>	55	<b>140</b>	55	<b>160</b>	37	<b>160</b>	30	<b>160</b>	60	140
									65	140
<b>280 S</b>	75	<b>160</b>	75	<b>180</b>	45	<b>180</b>	37	<b>180</b>	65	140
									75	140
<b>280 M</b>	90	<b>160</b>	90	<b>180</b>	55	<b>180</b>	45	<b>180</b>	65	140
									75	140
<b>315 S</b>	110	<b>160</b>	110	<b>200</b>	75	<b>200</b>	55	<b>200</b>	65	140
									80	170
<b>315 M</b>	132	<b>160</b>	132	<b>200</b>	90	<b>200</b>	75	<b>200</b>	65	140
									80	170

# FLENDER Standard Couplings

## Flexible Couplings - N-EUPEX and N-EUPEX DS Series

Type A for easy elastomer flexible replacement

### Selection and ordering data

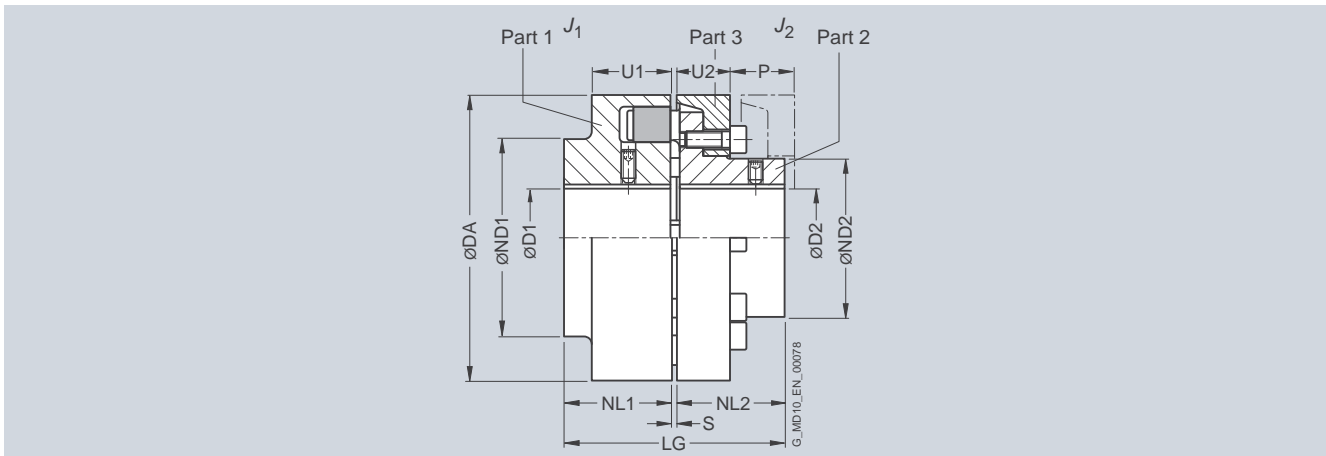

Size	Rated torque flexible type 80 ShoreA $T_{KN}$ Nm	Speed $n_{Kmax}$ rpm	Dimensions in mm											Mass moment of inertia $J_1/J_2$ kgm <sup>2</sup>	Product code Order codes for bore diameters and tolerances are specified in catalog section 3	Weight $m$ kg	
			Bore with keyway to DIN 6885		DA	ND1	ND2	NL1/ NL2	S	U1	U2	P	LG				
D1 min.	D2 max.	D1 min.	D2 max.														
110	160	5300	48	38	110	86	62	40	3	34	20	33	83	0.003	2LC0100-4AB ■ ■ -0AA0	3	
125	240	5100	55	45	125	100	75	50	3	36	23	38	103	0.005	2LC0100-5AB ■ ■ -0AA0	4.8	
140	360	4900	60	50	140	100	82	55	3	34	28	43	113	0.008	2LC0100-6AB ■ ■ -0AA0	6	
160	560	4250	65	58	160	108	95	60	4	39	28	47	124	0.014	2LC0100-7AB ■ ■ -0AA0	8.4	
180	880	3800	75	65	180	125	108	70	4	42	30	50	144	0.025	2LC0100-8AB ■ ■ -0AA0	12	
200	1340	3400	85	75	200	140	122	80	4	47	32	53	164	0.04	2LC0101-0AB ■ ■ -0AA0	17	
225	2000	3000	90	85	225	150	138	90	4	52	38	61	184	0.08	2LC0101-1AB ■ ■ -0AA0	23	
250	2800	2750	46	100	95	250	165	155	100	6	60	42	69	0.13	2LC0101-2AB ■ ■ -0AA0	31	
280	3900	2450	49	110	54	105	280	180	172	110	6	65	42	73	0.20	2LC0101-3AB ■ ■ -0AA0	41
315	5500	2150	49	100	46	100	315	165	165	125	6	70	47	78	0.32	2LC0101-4AB ■ ■ -0AA0	57
			90	120	90	120	200	200						0.35		61	
350	7700	2000	61	110	61	110	350	180	180	140	6	74	51	83	0.54	2LC0101-5AB ■ ■ -0AA0	78
			90	140	90	140	230	230						0.61		82	
400	10300	1700	66	120	66	120	400	200	200	160	6	78	56	88	1.0	2LC0101-6AB ■ ■ -0AA0	112
			100	150	100	150	250	250						1.1		117	
440	13500	1550	80	130	80	130	440	215	215	180	7	86	64	99	1.5	2LC0101-7AB ■ ■ -0AA0	147
			120	160	120	160	265	265						1.7		155	
480	16600	1400	90	145	90	145	480	240	240	190	7	90	65	104	2.3	2LC0101-8AB ■ ■ -0AA0	184
			136	180	136	180	300	300						2.6		200	
520	21200	1300	100	150	100	150	520	250	250	210	7	102	68	115	3.3	2LC0102-0AB ■ ■ -0AA0	234
			140	190	140	190	315	315						3.7		254	
560	29000	1200	120	200	120	200	560	320	320	220	9	115	80	125	6.0	2LC0102-1AB ■ ■ -0AA0	329
610	38000	1100	130	220	130	220	610	352	352	240	9	121	88	135	9.0	2LC0102-2AB ■ ■ -0AA0	416
660	49000	1000	140	240	140	240	660	384	384	260	9	132	96	145	13.5	2LC0102-3AB ■ ■ -0AA0	546
710	62000	1000	140	260	140	260	710	416	416	290	9	138	102	155	19	2LC0102-4AB ■ ■ -0AA0	680
ØD1:	<ul style="list-style-type: none"> <li>Without finished bore – Without order codes</li> <li>Without finished bore sizes 315 to 520 for 2nd diameter range D1 – Without order codes</li> <li>With finished bore – With order codes for diameter and tolerance (product code without <b>-Z</b>)</li> </ul>															1	
																2	
																9	
ØD2:	<ul style="list-style-type: none"> <li>Without finished bore – Without order codes</li> <li>Without finished bore sizes 315 to 520 for 2nd diameter range D2 – Without order codes</li> <li>With finished bore – With order codes for diameter and tolerance (product code without <b>-Z</b>)</li> </ul>															1	
																2	
																9	

The hub diameter of the component part is assigned according to the diameter of the finished bore. Where bore diameters overlap, the component with the smaller hub diameter is always selected.

Weights and mass moments of inertia apply to maximum bore diameters.

The product code applies to standard flexibles of 80 ShoreA; the product code for alternative flexible types is available on request.

**Ordering example:**  
N-EUPEX A coupling, size 200,  
Part 1: Bore D1 65H7 mm, keyway to DIN 6885-1 and set screw,  
Part 2: Bore D2 50H7 mm, keyway to DIN 6885-1 and set screw.

Product code:  
**2LC0101-0AB99-0AA0**  
**L1F+M1C**

# FLENDER Standard Couplings

## Flexible Couplings - N-EUPEX and N-EUPEX DS Series

Type B

### Selection and ordering data

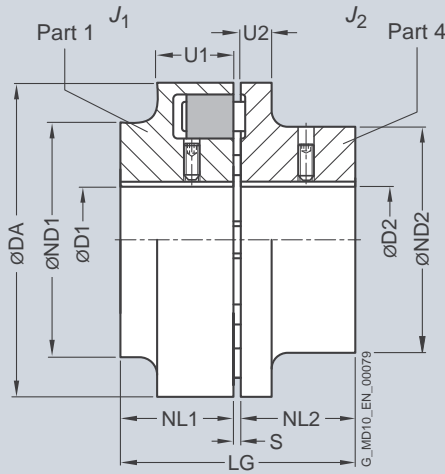

Size	Rated torque flexible type 80 ShoreA $T_{KN}$ Nm	Speed $n_{Kmax}$ rpm	Dimensions in mm										Mass moment of inertia $J_1/J_2$ kgm <sup>2</sup>	Product code Order codes for bore diameters and tolerances are specified in catalog section 3	Weight $m$ kg				
			Bore with keyway to DIN 6885		D1		D2		DA		ND1					ND2		NL1/ S NL2	
			min.	max.	min.	max.	min.	max.	min.	max.	min.	max.	min.	max.	min.	max.			
<b>58</b>	19	7500	19	24	58	58	40	20	3	20	8	43	0.0001	<b>2LC0100-0AA</b> ■ ■ ■ <b>-0AA0</b>	0.4				
<b>68</b>	34	7000	24	28	68	68	50	20	3	20	8	43	0.0002	<b>2LC0100-1AA</b> ■ ■ ■ <b>-0AA0</b>	0.54				
<b>80</b>	60	6000	30	38	80	80	68	30	3	30	10	63	0.0006	<b>2LC0100-2AA</b> ■ ■ ■ <b>-0AA0</b>	1.3				
<b>95</b>	100	5500	42	42	95	76	76	35	3	30	12	73	0.0013	<b>2LC0100-3AA</b> ■ ■ ■ <b>-0AA0</b>	2.2				
<b>110</b>	160	5300	48	48	110	86	86	40	3	34	14	83	0.003	<b>2LC0100-4AA</b> ■ ■ ■ <b>-0AA0</b>	3.3				
<b>125</b>	240	5100	55	55	125	100	100	50	3	36	18	103	0.006	<b>2LC0100-5AA</b> ■ ■ ■ <b>-0AA0</b>	5.2				
<b>140</b>	360	4900	60	60	140	100	100	55	3	34	20	113	0.007	<b>2LC0100-6AA</b> ■ ■ ■ <b>-0AA0</b>	5.6				
<b>160</b>	560	4250	65	65	160	108	108	60	4	39	20	124	0.01	<b>2LC0100-7AA</b> ■ ■ ■ <b>-0AA0</b>	7.8				
<b>180</b>	880	3800	75	75	180	125	125	70	4	42	20	144	0.02	<b>2LC0100-8AA</b> ■ ■ ■ <b>-0AA0</b>	11.5				
<b>200</b>	1340	3400	85	85	200	140	140	80	4	47	24	164	0.04	<b>2LC0101-0AA</b> ■ ■ ■ <b>-0AA0</b>	16				
<b>225</b>	2000	3000	90	90	225	150	150	90	4	52	18	184	0.07	<b>2LC0101-1AA</b> ■ ■ ■ <b>-0AA0</b>	20				
<b>250</b>	2800	2750	46	100	46	100	250	165	165	100	6	60	18	206	0.12	<b>2LC0101-2AA</b> ■ ■ ■ <b>-0AA0</b>	29		
<b>280</b>	3900	2450	49	110	54	110	280	180	180	110	6	65	20	226	0.18	<b>2LC0101-3AA</b> ■ ■ ■ <b>-0AA0</b>	38		
ØD1: <ul style="list-style-type: none"> <li>Without finished bore – Without order codes</li> <li>With finished bore – With order codes for diameter and tolerance (product code without <b>-Z</b>)</li> </ul>															1 9				
ØD2: <ul style="list-style-type: none"> <li>Without finished bore – Without order codes</li> <li>With finished bore – With order codes for diameter and tolerance (product code without <b>-Z</b>)</li> </ul>															1 9				

Weights and mass moments of inertia apply to maximum bore diameters.

**Ordering example:**

N-EUPEX B coupling, size 95,  
 Part 1: Bore D1 42H7 mm, keyway to DIN 6885-1 and set screw,  
 Part 2: Bore D2 32H7 mm, keyway to DIN 6885-1 and set screw.

Product code:  
**2LC0100-3AA99-0AA0**  
**LOX+MOT**

The product code applies to standard flexibles of 80 ShoreA; the product code for alternative flexible types is available on request.

# FLENDER Standard Couplings

## Flexible Couplings - N-EUPEX and N-EUPEX DS Series

### Type H

#### Selection and ordering data

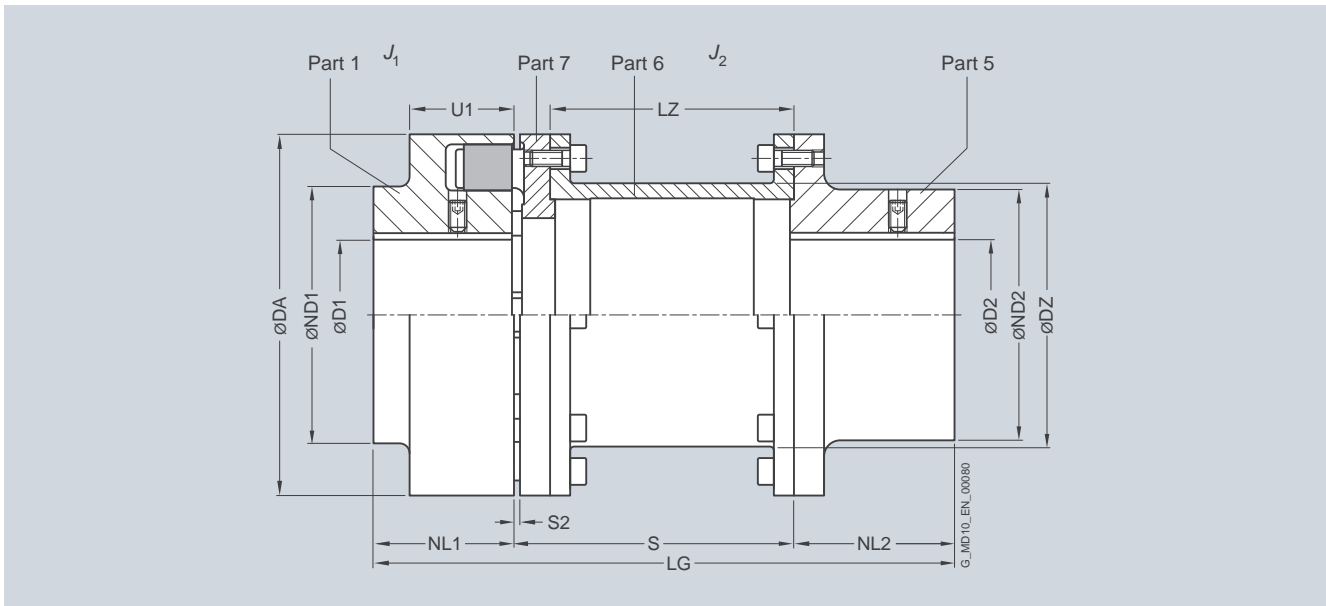

For dimension U1, see type A

Size	Rated torque flexible type 80 ShoreA $T_{KN}$ Nm	Speed $n_{Kmax}$ rpm	Dimensions in mm Bore with keyway to DIN 6885													Mass moment of inertia		Product code Order codes for bore diameters and tolerances are specified in catalog section 3	Weight $m$ kg	
			D1 min.	D2 max.	DA	ND1	ND2	NL1	NL2	S2	S	LZ	DZ	LG	$J_1$	$J_2$				
<b>80</b>	60	6000	30	32	80	80	55	30	45	5	100	87	51	175	0.0006	0.001	<b>2LC0100-2AG</b> ■ ■ ■ <b>-0AA0</b>	2.6		
											140	127	215	0.001					<b>2LC0100-2AG</b> ■ ■ ■ <b>-0AB0</b>	2.7
<b>95</b>	100	5500	42	42	95	76	70	35	45	5	100	87	63	180	0.001	0.003	<b>2LC0100-3AG</b> ■ ■ ■ <b>-0AA0</b>	3.5		
											140	127	220	0.003					<b>2LC0100-3AG</b> ■ ■ ■ <b>-0AB0</b>	3.8
<b>110</b>	160	5300	48	48	110	86	80	40	50	5	100	85	73	190	0.003	0.005	<b>2LC0100-4AG</b> ■ ■ ■ <b>-0AA0</b>	5.2		
											140	125	230	0.006					<b>2LC0100-4AG</b> ■ ■ ■ <b>-0AB0</b>	5.4
											180	165	280	0.006					<b>2LC0100-4AG</b> ■ ■ ■ <b>-0AC0</b>	6.0
<b>125</b>	240	5100	55	55	125	100	90	50	50	5	100	85	85	200	0.005	0.01	<b>2LC0100-5AG</b> ■ ■ ■ <b>-0AA0</b>	7.2		
											140	125	240	0.01					<b>2LC0100-5AG</b> ■ ■ ■ <b>-0AB0</b>	7.7
											180	165	290	0.011					<b>2LC0100-5AG</b> ■ ■ ■ <b>-0AC0</b>	8.2
											200	185	320	0.012					<b>2LC0100-5AG</b> ■ ■ ■ <b>-0AD0</b>	8.5
											250	235	380	0.012					<b>2LC0100-5AG</b> ■ ■ ■ <b>-0AE0</b>	9
<b>140</b>	360	4900	60	60	140	100	100	55	65	5	100	82	91	220	0.007	0.018	<b>2LC0100-6AG</b> ■ ■ ■ <b>-0AA0</b>	10.0		
											140	122	260	0.019					<b>2LC0100-6AG</b> ■ ■ ■ <b>-0AB0</b>	10.5
											180	162	300	0.02					<b>2LC0100-6AG</b> ■ ■ ■ <b>-0AC0</b>	11.0
											200	182	320	0.021					<b>2LC0100-6AG</b> ■ ■ ■ <b>-0AD0</b>	11.3
											250	232	385	0.022					<b>2LC0100-6AG</b> ■ ■ ■ <b>-0AE0</b>	12.0
<b>160</b>	560	4250	65	65	160	108	108	60	70	6	100	81.5	111	230	0.013	0.03	<b>2LC0100-7AG</b> ■ ■ ■ <b>-0AA0</b>	13		
											140	121.5	270	0.032					<b>2LC0100-7AG</b> ■ ■ ■ <b>-0AB0</b>	13.7
											180	161.5	310	0.034					<b>2LC0100-7AG</b> ■ ■ ■ <b>-0AC0</b>	14.5
											200	181.5	330	0.035					<b>2LC0100-7AG</b> ■ ■ ■ <b>-0AD0</b>	14.9
											250	231.5	390	0.037					<b>2LC0100-7AG</b> ■ ■ ■ <b>-0AE0</b>	15.9
<b>180</b>	880	3800	75	75	180	125	125	70	80	6	140	121.5	131	290	0.023	0.054	<b>2LC0100-8AG</b> ■ ■ ■ <b>-0AB0</b>	18.5		
											180	161.5	330	0.058					<b>2LC0100-8AG</b> ■ ■ ■ <b>-0AC0</b>	19.4
											200	181.5	350	0.060					<b>2LC0100-8AG</b> ■ ■ ■ <b>-0AD0</b>	21
											250	231.5	400	0.065					<b>2LC0100-8AG</b> ■ ■ ■ <b>-0AE0</b>	22

- |      |  |   |
|------|--|---|
| ØD1: | • Without finished bore – Without order codes  | 1 |
|      | • With finished bore – With order codes for diameter and tolerance (product code without <b>-Z</b> ) | 9 |
| ØD2: | • Without finished bore – Without order codes  | 1 |
|      | • With finished bore – With order codes for diameter and tolerance (product code without <b>-Z</b> ) | 9 |

# FLENDER Standard Couplings

## Flexible Couplings - N-EUPEX and N-EUPEX DS Series

Type H

Size	Rated torque flexible type 80 ShoreA $T_{KN}$ Nm	Speed $n_{Kmax}$ rpm	Dimensions in mm Bore with keyway to DIN 6885														Mass moment of inertia		Product code Order codes for bore diameters and tolerances are specified in catalog section 3	Weight $m$ kg								
			D1		D2		DA	ND1	ND2	NL1	NL2	S2	S	LZ	DZ	LG	$J_1$	$J_2$										
			min.	max.	min.	max.																						
<b>200</b>	1340	3400	85	85	200	140	140	80	90	6	140	118.5	144	310	0.04	0.095	<b>2LC0101-0AG</b> ■ ■ ■ <b>-0AB0</b>	25.6										
																					<b>2LC0101-0AG</b> ■ ■ ■ <b>-0AC0</b>	26.5						
																							<b>2LC0101-0AG</b> ■ ■ ■ <b>-0AD0</b>	27.2				
																								<b>2LC0101-0AG</b> ■ ■ ■ <b>-0AE0</b>	28.5			
<b>225</b>	2000	3000	90	90	225	150	150	90	100	6	140	118.5	169	330	0.07	0.158	<b>2LC0101-1AG</b> ■ ■ ■ <b>-0AB0</b>	34										
																							<b>2LC0101-1AG</b> ■ ■ ■ <b>-0AC0</b>	35				
																									<b>2LC0101-1AG</b> ■ ■ ■ <b>-0AD0</b>	36		
																									<b>2LC0101-1AG</b> ■ ■ ■ <b>-0AE0</b>	38		
<b>250</b>	2800	2750	46	100	46	100	250	165	165	100	110	8	180	152.5	185	390	0.12	0.27	<b>2LC0101-2AG</b> ■ ■ ■ <b>-0AC0</b>	48								
																										<b>2LC0101-2AG</b> ■ ■ ■ <b>-0AD0</b>	50	
																											<b>2LC0101-2AG</b> ■ ■ ■ <b>-0AE0</b>	52
<b>280</b>	3900	2450	49	110	51	110	280	180	180	110	120	8	250	222.5	215	480	0.20	0.52	<b>2LC0101-3AG</b> ■ ■ ■ <b>-0AE0</b>	70								
<b>315</b>	5500	2150	49	100	51	120	315	165	200	125	140	8	250	222.5	250	515	0.32	0.87	<b>2LC0101-4AG</b> ■ ■ ■ <b>-0AE0</b>	98								
<b>350</b>	7700	2000	61	110	51	140	350	180	230	140	150	8	250	220.5	272	540	0.54	1.4	<b>2LC0101-5AG</b> ■ ■ ■ <b>-0AE0</b>	120								
<b>400</b>	10300	1700	66	120	51	150	400	200	250	160	180	8	250	185.5	310	590	1.0	2.9	<b>2LC0101-6AG</b> ■ ■ ■ <b>-0AE0</b>	195								
<b>440</b>	13500	1550	80	130	51	160	440	215	265	180	180	10	250	182	354	610	1.5	4.1	<b>2LC0101-7AG</b> ■ ■ ■ <b>-0AE0</b>	225								
			ØD1:		<ul style="list-style-type: none"> <li>Without finished bore – Without order codes</li> <li>Without finished bore sizes 315 to 440 for 2nd diameter range D1 – Without order codes</li> <li>With finished bore – With order codes for diameter and tolerance (product code without <b>-Z</b>)</li> </ul>															1 2 9								
			ØD2:		<ul style="list-style-type: none"> <li>Without finished bore – Without order codes</li> <li>Without finished bore sizes 315 to 440 for 2nd diameter range D2 – Without order codes</li> <li>With finished bore – With order codes for diameter and tolerance (product code without <b>-Z</b>)</li> </ul>															1 2 9								

During assembly, the gap dimension S2 must not exceed the permissible tolerance of +1 mm.

The hub diameter of the component part is assigned according to the diameter of the finished bore. Where bore diameters overlap, the component with the smaller hub diameter is always selected.

Weights and mass moments of inertia apply to maximum bore diameters.

Ordering example:

N-EUPEX H coupling, size 160, S = 200 mm,  
Part 1: Bore D1 60H7 mm, keyway to DIN 6885-1 and set screw,  
Part 2: Bore D2 55H7 mm, keyway to DIN 6885-1 and set screw.

Product code:  
**2LC0100-7AG99-0AD0**  
**L1E+M1D**

The product code applies to standard flexibles of 80 ShoreA; the product code for alternative flexible types is available on request.



# FLENDER Standard Couplings

## Flexible Couplings - N-EUPEX and N-EUPEX DS Series

Type D for easy elastomer flexible replacement

### Selection and ordering data

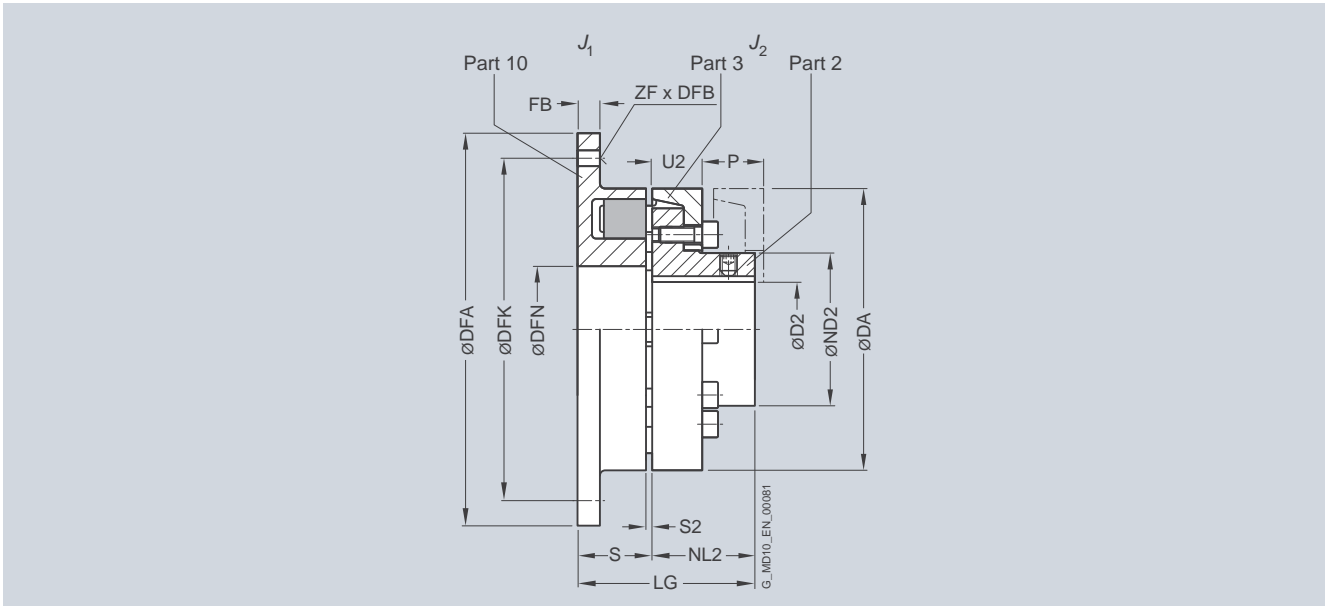

For dimensions U2 and P, see type A

Size	Rated torque flexible type 80 ShoreA $T_{KN}$ Nm	Speed $n_{Kmax}$ rpm	Dimensions in mm																Mass moment of inertia		Product code Order codes for bore diameters and tolerances are specified in catalog section 3	Weight $m$ kg
			Bore with keyway to DIN 6885		Flange connection dimensions														$J_1$	$J_2$		
			D2 min.	DA max.	ND2	NL2	S2	S	LG	DFA h8	DFN h7	DFK	FB	ZF	DFB	$J_1$	$J_2$					
110	160	5300	38	110	62	40	3	30	70	144	62	128	10	6	9	0.003	0.003	2LC0100-4AD1	-0AA0	2.7		
															M8						2LC0100-4AD2	-0AA0
125	240	5100	45	125	75	50	3	34	84	158	75	142	10	6	9	0.005	0.005	2LC0100-5AD1	-0AA0	3.9		
															M8						2LC0100-5AD2	-0AA0
140	360	4900	50	140	82	55	3	37	92	180	82	160	13	6	11	0.011	0.008	2LC0100-6AD1	-0AA0	5.6		
															M10						2LC0100-6AD2	-0AA0
160	560	4250	58	160	95	60	4	43	103	200	95	180	13	7	11	0.017	0.014	2LC0100-7AD1	-0AA0	7.5		
															M10						2LC0100-7AD2	-0AA0
180	880	3800	65	180	108	70	4	46	116	220	110	200	13	8	11	0.026	0.025	2LC0100-8AD1	-0AA0	10.3		
															M10						2LC0100-8AD2	-0AA0
200	1340	3400	75	200	122	80	4	51	131	248	120	224	16	8	14	0.051	0.04	2LC0101-0AD1	-0AA0	14.7		
															M12						2LC0101-0AD2	-0AA0
225	2000	3000	85	225	138	90	4	56	146	274	135	250	16	8	14	0.085	0.08	2LC0101-1AD1	-0AA0	19.5		
															M12						2LC0101-1AD2	-0AA0
250	2800	2750	95	250	155	100	5	65	165	314	150	282	20	8	18	0.16	0.13	2LC0101-2AD1	-0AA0	28.0		
															M16						2LC0101-2AD2	-0AA0
280	3900	2450	54	105	280	172	110	5	70	180	344	170	312	20	18	0.24	0.2	2LC0101-3AD1	-0AA0	35.0		
															M16						2LC0101-3AD2	-0AA0
315	5500	2150	46	100	315	165	125	5	75	200	380	200	348	22	9	18	0.4	0.32	2LC0101-4AD1	-0AA0	47	
			90	120	200													0.35				
	5500	2150	46	100	315	165	125	5	75	200	380	200	348	22	9	M16	0.4	0.32	2LC0101-4AD2	-0AA0	47	
			90	120	200													0.35				
350	7700	2000	61	110	350	180	140	5	79	219	430	225	390	25	9	22	0.7	0.54	2LC0101-5AD1	-0AA0	64	
			90	140	230													0.61				
	7700	2000	61	110	350	180	140	5	79	219	430	225	390	25	9	M20	0.7	0.54	2LC0101-5AD2	-0AA0	64	
			90	140	230													0.61				
400	10300	1700	66	120	400	200	160	5	83	243	480	265	440	25	10	22	1.1	1.0	2LC0101-6AD1	-0AA0	86	
			100	150	250													1.1				
	10300	1700	66	120	400	200	160	5	83	243	480	265	440	25	10	M20	1.1	1.0	2LC0101-6AD2	-0AA0	86	
			100	150	250													1.1				

ØD2:   
 • Without finished bore – Without order codes 1  
 • Without finished bore – Only for sizes 315 to 520 in each case with a larger diameter D2 – Without order codes 2  
 • With finished bore – With order codes for diameter and tolerance (product code without -Z) 9

# FLENDER Standard Couplings

## Flexible Couplings - N-EUPEX and N-EUPEX DS Series

Type D for easy elastomer flexible replacement

Size	Rated torque flexible type 80 ShoreA $T_{KN}$ Nm	Speed $n_{Kmax}$ rpm	Dimensions in mm														Mass moment of inertia		Product code Order codes for bore diameters and tolerances are specified in catalog section 3	Weight $m$ kg
			Bore with keyway to DIN 6885		Flange connection dimensions												$J_1$	$J_2$		
			D2 min.	max.	DA	ND2	NL2	S2	S	LG	DFA h8	DFN H7	DFK	FB	ZF	DFB				
440	13500	1550	80	130	440	215	180	8	94	274	520	295	480	25	10	22	1.7	1.5	2LC0101-7AD1 ■ -0AA0	114
			120	160		265														1.7
480	16600	1400	80	130	440	215	180	8	94	274	520	295	480	25	10	M20	1.7	1.5	2LC0101-7AD2 ■ -0AA0	114
			120	160		265														1.7
480	16600	1400	90	145	480	240	190	8	98	288	575	325	528	30	10	26	2.7	2.3	2LC0101-8AD1 ■ -0AA0	146
			136	180		300														2.6
520	16600	1400	90	145	480	240	190	8	98	288	575	325	528	30	10	M24	2.7	2.3	2LC0101-8AD2 ■ -0AA0	146
			136	180		300														2.6
520	21200	1300	100	150	520	250	210	8	110	320	615	355	568	30	10	26	3.8	3.3	2LC0102-0AD1 ■ -0AA0	177
			140	190		315														3.7
520	21200	1300	100	150	520	250	210	8	110	320	615	355	568	30	10	M24	3.8	3.3	2LC0102-0AD2 ■ -0AA0	177
			140	190		315														3.7

- ØD2:
- Without finished bore – Without order codes
  - Without finished bore – Only for sizes 315 to 520 in each case with a larger diameter D2 – Without order codes
  - With finished bore – With order codes for diameter and tolerance (product code without **-Z**)

1  
2  
9

The hub diameter of the component part is assigned according to the diameter of the finished bore. Where bore diameters overlap, the component with the smaller hub diameter is always selected.

Weights and mass moments of inertia apply to maximum bore diameters.

#### Ordering example:

N-EUPEX D coupling, size 125,

Part 10: with through bores,

Part 2: Bore D2 38H7 mm, with keyway to DIN 6885-1 and set screw.

Product code:

**2LC0100-5AD19-0AA0**

**MOV**

The product code applies to standard flexibles of 80 ShoreA; the product code for alternative flexible types is available on request.

# FLENDER Standard Couplings

## Flexible Couplings - N-EUPEX and N-EUPEX DS Series

### Type E

#### Selection and ordering data

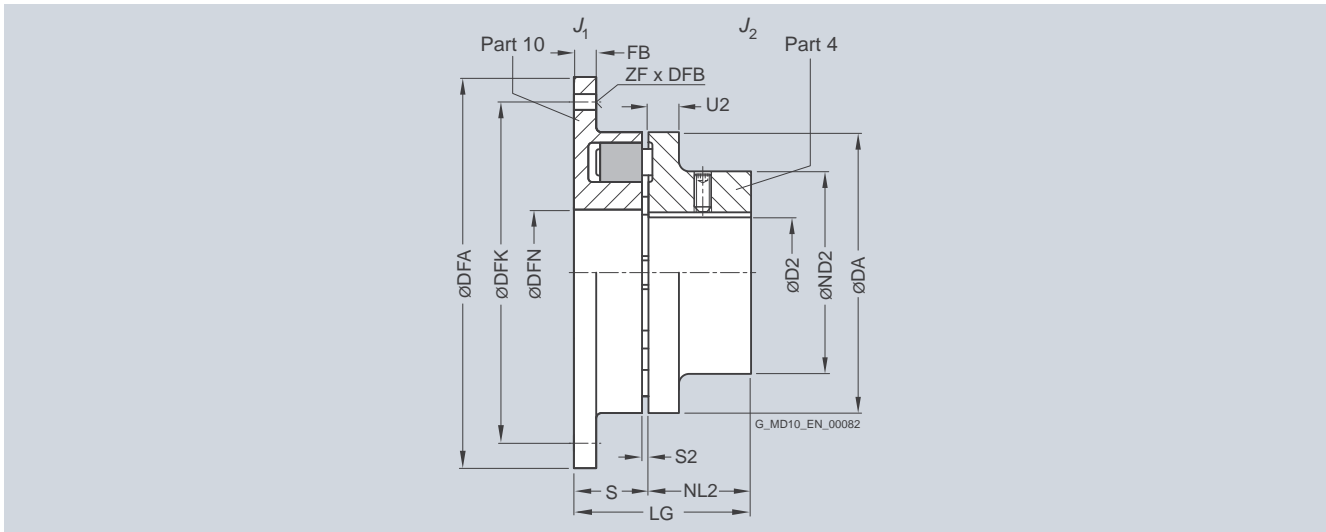

For dimension U2, see type B

Size	Rated torque flexible type 80 ShoreA $T_{KN}$ Nm	Speed $n_{Kmax}$ rpm	Dimensions in mm										Mass moment of inertia		Product code Order codes for bore diameters and tolerances are specified in catalog section 3	Weight $m$ kg			
			Bore with keyway to DIN 6885			Flange connection dimensions							$J_2$	$J_1$					
			D2 from to	DA	ND2	NL2	S2	S	LG	DFA h8	DFN H7	DFK	FB	ZF	DFB				
<b>68</b>	34	7000	28 68	50	20	3	23	43	90	34	80	7	6	5.5	0.0004	0.0002	<b>2LC0100-1AC1 -0AA0</b>	0.63	
														M5			<b>2LC0100-1AC2 -0AA0</b>		
<b>80</b>	60	6000	38 80	68	30	3	24	54	106	42	94	8	6	6.6	0.0008	0.0006	<b>2LC0100-2AC1 -0AA0</b>	1.35	
														M6			<b>2LC0100-2AC2 -0AA0</b>		
<b>95</b>	100	5500	42 95	76	35	3	27	62	120	52	108	8	6	6.6	0.0014	0.0013	<b>2LC0100-3AC1 -0AA0</b>	2.0	
														M6			<b>2LC0100-3AC2 -0AA0</b>		
<b>110</b>	160	5300	48 110	86	40	3	30	70	144	62	128	10	6	9	0.0034	0.0030	<b>2LC0100-4AC1 -0AA0</b>	3.0	
														M8			<b>2LC0100-4AC2 -0AA0</b>		
<b>125</b>	240	5100	55 125	100	50	3	34	84	158	75	142	10	6	9	0.0052	0.0060	<b>2LC0100-5AC1 -0AA0</b>	4.5	
														M8			<b>2LC0100-5AC2 -0AA0</b>		
<b>140</b>	360	4900	60 140	100	55	3	37	92	180	82	160	13	6	11	0.011	0.007	<b>2LC0100-6AC1 -0AA0</b>	5.6	
														M10			<b>2LC0100-6AC2 -0AA0</b>		
<b>160</b>	560	4250	65 160	108	60	4	43	103	200	95	180	13	7	11	0.017	0.01	<b>2LC0100-7AC1 -0AA0</b>	7.2	
														M10			<b>2LC0100-7AC2 -0AA0</b>		
<b>180</b>	880	3800	75 180	125	70	4	46	116	220	110	200	13	8	11	0.026	0.02	<b>2LC0100-8AC1 -0AA0</b>	10.3	
														M10			<b>2LC0100-8AC2 -0AA0</b>		
<b>200</b>	1340	3400	85 200	140	80	4	51	131	248	120	224	16	8	14	0.051	0.04	<b>2LC0101-0AC1 -0AA0</b>	14	
														M12			<b>2LC0101-0AC2 -0AA0</b>		
<b>225</b>	2000	3000	90 225	150	90	4	56	146	274	135	250	16	8	14	0.085	0.7	<b>2LC0101-1AC1 -0AA0</b>	17	
														M12			<b>2LC0101-1AC2 -0AA0</b>		
<b>250</b>	2800	2750	46 100	250	165	100	5	65	165	314	150	282	20	18	0.16	0.12	<b>2LC0101-2AC1 -0AA0</b>	26	
														M16			<b>2LC0101-2AC2 -0AA0</b>		
<b>280</b>	3900	2450	54 110	280	180	110	5	70	180	344	170	312	20	18	0.24	0.13	<b>2LC0101-3AC1 -0AA0</b>	32	
														M16			<b>2LC0101-3AC2 -0AA0</b>		

øD2:   
 • Without finished bore – Without order codes 1  
 • With finished bore – With order codes for diameter and tolerance (product code without -Z) 9

Weights and mass moments of inertia apply to maximum bore diameters.

Ordering example:  
 N-EUPEX E coupling, size 125,  
 Part 10 with through bores,  
 Part 4: Bore D2 38H7 mm, keyway to DIN 6885-1 and set screw.

Product code:  
**2LC0100-5AC19-0AA0**  
**M0V**

The product code applies to standard flexibles of 80 ShoreA; the product code for alternative flexible types is available on request.



# FLENDER Standard Couplings

## Flexible Couplings - N-EUPEX and N-EUPEX DS Series

**Type P with brake drum  
for easy elastomer replacement**

### Selection and ordering data

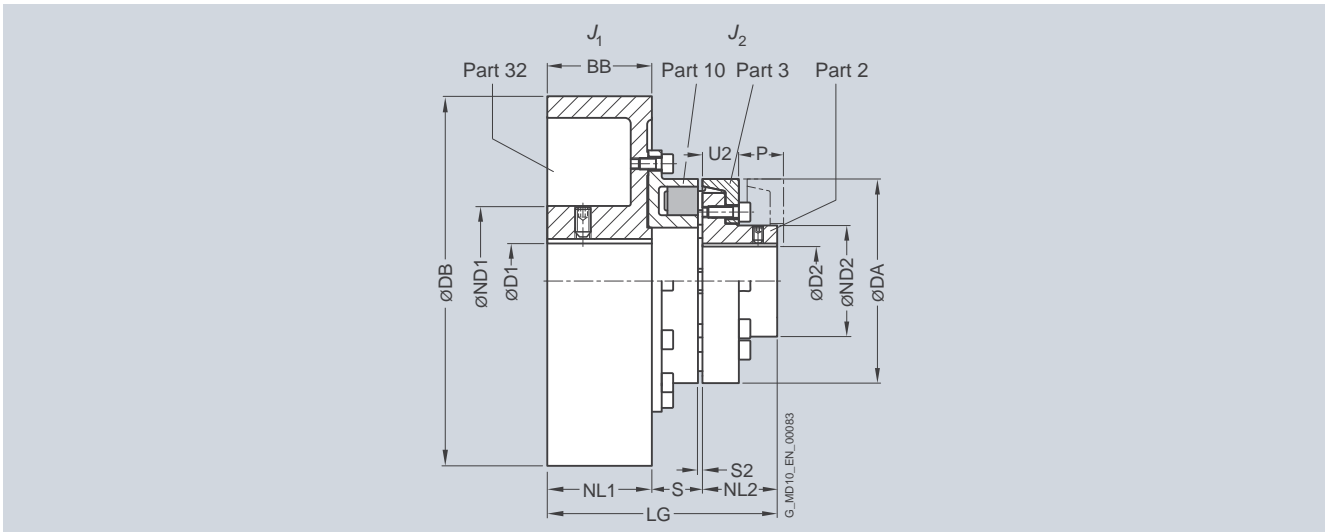

For dimensions U2 and P, see type A

Size	Rated torque flexible type 80 ShoreA $T_{KN}$ Nm	Speed $n_{kmax}$ rpm	Dimensions in mm Bore with keyway to DIN 6885													Mass moment of inertia		Product code Order codes for bore diameters and tolerances are specified in catalog section 3	Weight $m$ kg	
			D1 min.	D2 min.	DA min.	ND1 min.	ND2 min.	NL1/BB min.	NL2 min.	S2 min.	S min.	DB min.	U2 min.	LG min.	$J_1$ kgm <sup>2</sup>	$J_2$ kgm <sup>2</sup>				
125	240	3400	55	45	125	84	75	75	50	3	31	200	23	156	0.043	0.004	2LC0100-5AF11 ■ ■ -0BA0	10.9		
	140	2750	60	50	140	128	82	95	55	3	34	250	28	184	0.13	0.008		2LC0100-6AF11 ■ ■ -0CA0	21	
160	560	2750	70	58	160	128	95	95	60	4	40	250	28	195	0.14	0.014	2LC0100-7AF11 ■ ■ -0CA0	22		
	180	2750	70	65	180	128	108	95	70	4	41	250	30	206	0.16	0.025		2LC0100-8AF11 ■ ■ -0CA0	28	
200	1340	2150	80	75	200	128	122	118	80	4	48	315	32	246	0.37	0.04	2LC0101-0AF11 ■ ■ -0DA0	40		
		1700	90			160	150				48	400		278	1.1		2LC0101-0AF11 ■ ■ -0FA0	60		
		1400	110			175	190				48	500		318	2.8		2LC0101-0AF11 ■ ■ -0HA0	98		
225	2000	2150	80	85	225	128	138	118	90	4	51	315	38	259	0.39	0.08	2LC0101-1AF11 ■ ■ -0DA0	47		
		1700	90			160	150				53	400		293	1.1		2LC0101-1AF11 ■ ■ -0FA0	65		
		1400	38	110			175	190			53	500		333	3.1		2LC0101-1AF11 ■ ■ -0HA0	104		
250	2800	1700	100	95	250	160	155	150	100	5	63	400	42	313	1.16	0.13	2LC0101-2AF11 ■ ■ -0FA0	76		
		1400	38	110			175	190			63	500		353	2.9		2LC0101-2AF11 ■ ■ -0HA0	113		
280	3900	1700	100	54	105	280	160	172	150	110	5	65	400	42	325	1.24	0.2	2LC0101-3AF11 ■ ■ -0FA0	85	
		1400	48	110			175	190			68	500		368	3.1		2LC0101-3AF11 ■ ■ -0HA0	118		
		1100	48	110			175	236			68	630		414	8.0		2LC0101-3AF11 ■ ■ -0KA0	171		
315	5500	1700	100	46	100	315	160	165	150	125	5	73	400	47	348	1.4	0.32	2LC0101-4AF11 ■ ■ -0FA0	96	
		1400	48	110			175	190			73	500		388	3.3		2LC0101-4AF11 ■ ■ -0HA0	134		
		1100	48	110			175	236			73	630		434	8.2		2LC0101-4AF11 ■ ■ -0KA0	183		
		1000	55	120			192	265			73	710		463	14.2		2LC0101-4AF11 ■ ■ -0LA0	236		
315	5500	1700	100	90	120	315	160	200	150	125	5	73	400	47	348	1.4	0.35	2LC0101-4AF11 ■ ■ -0FA0	97	
		1400	48	110			175	190			73	500		388	3.3		2LC0101-4AF11 ■ ■ -0HA0	136		
		1100	48	110			175	236			73	630		434	8.2		2LC0101-4AF11 ■ ■ -0KA0	185		
		1000	55	120			192	265			73	710		463	14.2		2LC0101-4AF11 ■ ■ -0LA0	238		
350	7700	1100	48	110	61	110	350	175	180	236	140	5	76	630	51	452	8.5	0.54	2LC0101-5AF11 ■ ■ -0KA0	200
		1000	55	120			192	265			76	710		481	14.6		2LC0101-5AF11 ■ ■ -0LA0	253		
350	7700	1100	48	110	90	140	350	175	230	236	140	5	76	630	51	452	8.5	0.61	2LC0101-5AF11 ■ ■ -0KA0	203
		1000	55	120			192	265			76	710		481	14.6		2LC0101-5AF11 ■ ■ -0LA0	257		

- øD1:
  - Without finished bore – Without order codes
  - With finished bore – With order codes for diameter and tolerance (product code without -Z)
- øD2:
  - Without finished bore – Without order codes
  - With finished bore – With order codes for diameter and tolerance (product code without -Z)

Weights and mass moments of inertia apply to maximum bore diameters.

# FLENDER Standard Couplings

## Flexible Couplings - N-EUPEX and N-EUPEX DS Series

### Type O with brake drum

#### Selection and ordering data

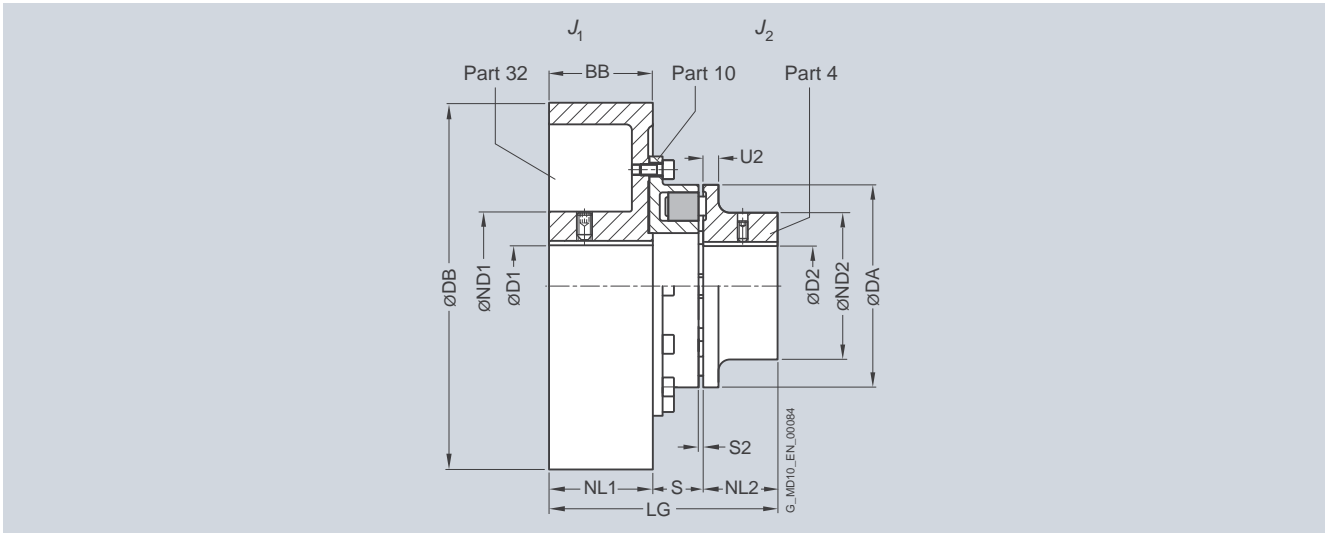

Size	Rated torque flexible type 80 ShoreA $T_{KN}$ Nm	Speed $n_{Kmax}$ rpm	Dimensions in mm														Mass moment of inertia		Product code Order codes for bore diameters and tolerances are specified in catalog section 3	Weight $m$ kg						
			Bore with keyway to DIN 6885		DA		ND1		ND2		NL1		NL2		S		DB				U2		LG		$J_1$	$J_2$
			min.	max.	min.	max.	min.	max.	min.	max.	min.	max.	min.	max.	min.	max.	min.	max.			min.	max.	min.	max.	kgm <sup>2</sup>	kgm <sup>2</sup>
<b>125</b>	240	3400	55	55	125	84	100	75	50	3	31	200	18	156	0.043	0.006	<b>2LC0100-5AE</b>	<b>-0BA0</b>	11.3							
<b>140</b>	360	2750	60	60	140	128	100	95	55	3	34	250	20	184	0.13	0.007	<b>2LC0100-6AE</b>	<b>-0CA0</b>	22.3							
<b>160</b>	560	2750	70	65	160	128	108	95	60	4	40	250	20	195	0.14	0.01	<b>2LC0100-7AE</b>	<b>-0CA0</b>	24							
<b>180</b>	880	2150	70	75	180	128	125	95	70	4	41	250	20	206	0.16	0.02	<b>2LC0100-8AE</b>	<b>-0CA0</b>	28							
			80										43	315	231	0.35		<b>2LC0100-8AE</b>	<b>-0DA0</b>	35						
<b>200</b>	1340	2190	80	85	200	128	140	118	80	4	48	315	24	246	0.37	0.04	<b>2LC0101-0AE</b>	<b>-0DA0</b>	40							
		1700	90									48	400	278	1.10		<b>2LC0101-0AE</b>	<b>-0FA0</b>	60							
		1400	110									48	500	318	2.80		<b>2LC0101-0AE</b>	<b>-0HA0</b>	98							
<b>225</b>	2000	2150	80	90	225	128	150	118	90	4	51	315	18	259	0.39	0.07	<b>2LC0101-1AE</b>	<b>-0DA0</b>	45							
		1700	90									53	400	293	1.10		<b>2LC0101-1AE</b>	<b>-0FA0</b>	63							
		1400	38 110									53	500	333	3.10		<b>2LC0101-1AE</b>	<b>-0HA0</b>	102							
<b>250</b>	2800	1700	100	46 100	250	160	165	150	100	5	63	400	18	313	1.16	0.12	<b>2LC0101-2AE</b>	<b>-0FA0</b>	73							
		1400	38 110									63	500	353	2.90		<b>2LC0101-2AE</b>	<b>-0HA0</b>	108							
<b>280</b>	3900	1700	110	54 110	280	160	180	150	110	5	65	400	20	325	1.24	0.18	<b>2LC0101-3AE</b>	<b>-0FA0</b>	82							
		1400	48									68	500	368	3.10		<b>2LC0101-3AE</b>	<b>-0HA0</b>	115							
		1100	48									68	630	414	8.0		<b>2LC0101-3AE</b>	<b>-0KA0</b>	168							
ØD1: <ul style="list-style-type: none"> <li>Without finished bore – Without order codes</li> <li>With finished bore – With order codes for diameter and tolerance (product code without <b>-Z</b>)</li> </ul>																		1	9							
ØD2: <ul style="list-style-type: none"> <li>Without finished bore – Without order codes</li> <li>With finished bore – With order codes for diameter and tolerance (product code without <b>-Z</b>)</li> </ul>																		1	9							

Weights and mass moments of inertia apply to maximum bore diameters.

**Ordering example:**  
 N-EUPEX O coupling, size 200,  
 brake drum 315 x 118 mm,  
 Part 32: Bore D1 55H7 mm, keyway to DIN 6885 P9 and set screw,  
 Part 4: Bore D2 60H7 mm, keyway to DIN 6885 and set screw.

Coupling micro-balanced G6.3 at 1500 rpm in accordance with half parallel key standard.

**Product code:**  
**2LC0101-0AE99-0DA0-Z**  
**L1D+M1E+W02**

The product code applies to standard flexibles of 80 ShoreA; the product code for alternative flexible types is available on request.

# FLENDER Standard Couplings

## Flexible Couplings - N-EUPEX and N-EUPEX DS Series

Type DBDR with brake disk for easy elastomer flexible replacement

### Selection and ordering data

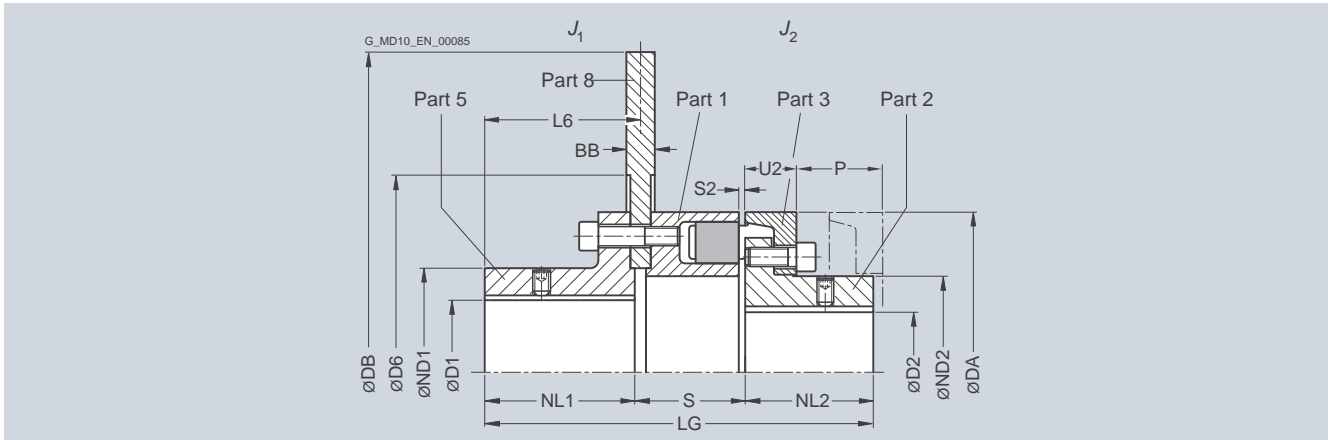

For dimensions U2 and P, see type A

Size	Rated torque flexible type 80 ShoreA $T_{KN}$ Nm	Dimensions in mm														Mass moment of inertia		Product code Plain text specification <b>DB; BB; D6; NL1</b> required for order code <b>P0Y</b> Order codes for bore diameters and tolerances are specified in catalog section 3	Weight $m$ min. kg	
		Bore with keyway to DIN 6885														$J_1$	$J_2$			
		D1	D2	DA	ND1	ND2	NL1	NL2	S	S2	DB	D6	BB	L6	LG	min. kgm <sup>2</sup>	kgm <sup>2</sup>			
		max.	min.	max.							min.	min.								
140	360	55	50	140	85	82	72	55	54.35	3	315	175	12.7	74	181.35	0.11	0.008	2LC0100-6AV ■ ■ -OZA0 P0Y	15.5	
							72								15	76	184.5		0.13	17
							188								30	200	316		0.24	28.5
160	560	70	58	160	105	95	90	60	58.35	4	315	175	12.7	91	208.35	0.12	0.014	2LC0100-7AV ■ ■ -OZA0 P0Y	19	
							90								15	94	212.5		0.14	20.5
							188								30	200	326		0.26	32
180	880	80	65	180	125	108	90	70	60.35	4	355	200	12.7	91	220.35	0.35	0.025	2LC0100-8AV ■ ■ -OZA0 P0Y	25.5	
							90								15	94	224.5		0.37	27
							188								30	200	338		0.57	43
200	1340	90	75	200	135	122	95	80	67.35	4	400	220	12.7	97	242.35	0.32	0.04	2LC0101-0AV ■ ■ -OZA0 P0Y	33	
							95								15	99	245.5		0.36	36
							188								30	200	354		0.67	55
225	2000	105	85	225	160	138	100	90	72.35	4	450	250	12.7	103	262.35	0.52	0.08	2LC0101-1AV ■ ■ -OZA0 P0Y	44	
							100								15	104	264.5		0.59	47
							188								30	200	368		1.1	72
250	2800	110	95	250	170	155	105	100	83.35	6	500	280	12.7	107	288.35	1.6	0.13	2LC0101-2AV ■ ■ -OZA0 P0Y	58	
							105								15	109	291.5		1.7	61
							188								30	200	390		2.5	90
280	3900	130	54	105	280	200	120	110	87.35	6	560	310	12.7	122	317.35	1.3	0.20	2LC0101-3AV ■ ■ -OZA0 P0Y	76	
							120								15	124	320.5		1.5	80
							188								30	200	404		2.7	115
315	5500	130	46	100	315	200	130	125	87.35	6	630	350	12.7	130	342.35	2.1	0.32	2LC0101-4AV ■ ■ -OZA0 P0Y	98	
							130								15	134	347.5		2.3	100
							188								30	200	421		4.2	140
315	5500	130	90	120	315	200	130	125	87.35	6	630	350	12.7	130	342.35	2.1	0.35	2LC0101-4AV ■ ■ -OZA0 P0Y	100	
							130								15	134	347.5		2.3	105
							188								30	200	421		4.2	145
350	7700	140	61	110	350	230	135	140	97.35	6	710	390	12.7	136	372.35	3.3	0.54	2LC0101-5AV ■ ■ -OZA0 P0Y	130	
							135								15	139	376.5		3.8	135
							188								30	200	445		6.7	190
350	7700	140	90	140	350	230	135	140	97.35	6	710	390	12.7	136	372.35	3.3	0.61	2LC0101-5AV ■ ■ -OZA0 P0Y	135	
							135								15	139	376.5		3.8	140
							188								30	200	445		6.7	190

- ØD1:
  - Without finished bore – Without order codes
  - With finished bore – With order codes for diameter and tolerance (product code without **-Z**) 1 9
- ØD2:
  - Without finished bore – Without order codes
  - With finished bore – With order codes for diameter and tolerance (product code without **-Z**) 1 9

Weights and mass moments of inertia apply to maximum bore diameters.

Maximum speed in rpm  
 $n_{max} = 1146/DB$  DB in m

Other brake disk diameters DB and brake disk widths BB on request.

# FLENDER Standard Couplings

## Flexible Couplings - N-EUPEX and N-EUPEX DS Series

**Type DBD with brake disk  
for easy elastomer flexible replacement**

### Selection and ordering data

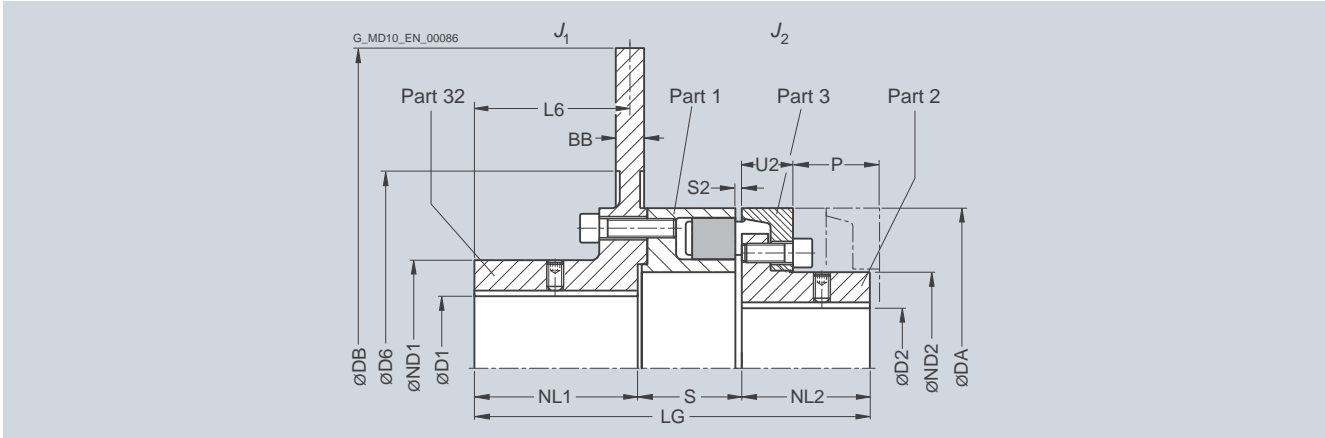

For dimensions U2 and P, see type A

Size	Rated torque flexible type 80 ShoreA $T_{KN}$ Nm	Dimensions in mm														Mass moment of inertia		Product code Plain text specification <b>DB</b> ; <b>BB</b> ; <b>D6</b> ; <b>NL1</b> required for order code <b>P0Y</b> Order codes for bore diameters and tolerances are specified in catalog section 3	Weight $m$ min. kg							
		Bore with keyway to DIN 6885			D1		D2		DA		ND1		ND2		NL1		NL2			S	S2	DB	D6	BB	L6	LG
		max.	min.	max.															min.	min.						
140	360	55	50	140	85	82	81.5	55	49.5	3	315	175	12.7	74	186	0.10	0.008	2LC0100-6AU ■ ■ -OZA0 P0Y	15							
		81.5												15	73	186	0.12			16						
		211.5												30	200	316	0.22			26						
160	560	70	58	160	105	95	98.5	60	54.5	4	315	175	12.7	91	213	0.11	0.014	2LC0100-7AU ■ ■ -OZA0 P0Y	18							
		98.5												15	90	213	0.13			19						
		211.5												30	200	326	0.23			30						
180	880	80	65	180	125	108	98.5	70	56.5	4	355	200	12.7	91	225	0.33	0.025	2LC0100-8AU ■ ■ -OZA0 P0Y	24							
		98.5												15	90	225	0.36			25.5						
		211.5												30	200	338	0.53			40						
200	1340	90	75	200	135	122	104.5	80	62.5	4	400	220	12.7	97	247	0.30	0.04	2LC0101-0AU ■ ■ -OZA0 P0Y	32.5							
		104.5												15	96	247	0.34			34						
		211.5												30	200	354	0.61			51						
225	2000	105	85	225	160	138	111.5	90	66.5	4	450	250	12.7	103	268	0.48	0.08	2LC0101-1AU ■ ■ -OZA0 P0Y	43							
		111.5												15	102	268	0.55			45						
		211.5												30	200	368	1.0			66						
250	2800	110	95	250	170	155	116.5	100	78.5	6	500	280	12.7	107	295	1.5	0.13	2LC0101-2AU ■ ■ -OZA0 P0Y	56							
		116.5												15	106	295	1.6			58						
		211.5												30	200	390	2.3			83						
280	3900	130	54	105	280	200	172	131.5	110	82.5	6	560	310	12.7	122	324	1.2	0.20	2LC0101-3AU ■ ■ -OZA0 P0Y	73						
		131.5												15	121	324	1.3			76						
		211.5												30	200	404	2.4			107						
315	5500	130	46	100	315	200	165	141.5	125	87.5	6	630	350	12.7	130	351	1.9	0.32	2LC0101-4AU ■ ■ -OZA0 P0Y	93						
		141.5												15	129	351	2.1			97						
		211.5												30	200	421	3.8			130						
315	5500	130	90	120	315	200	200	141.5	125	87.5	6	630	350	12.7	130	351	1.9	0.35	2LC0101-4AU ■ ■ -OZA0 P0Y	96						
		141.5												15	129	351	2.1			100						
		211.5												30	200	421	3.8			135						
350	7700	140	61	110	350	230	180	146.5	140	93.5	6	710	390	12.7	136	380	3.8	0.54	2LC0101-5AU ■ ■ -OZA0 P0Y	145						
		146.5												15	134	380	4.2			150						
		211.5												30	200	445	6.0			170						
350	7700	140	90	140	350	230	230	146.5	140	93.5	6	710	390	12.7	136	380	3.8	0.61	2LC0101-5AU ■ ■ -OZA0 P0Y	150						
		146.5												15	134	380	4.2			155						
		211.5												30	200	445	6.0			175						

- øD1:
  - Without finished bore – Without order codes
  - With finished bore – With order codes for diameter and tolerance (product code without **-Z**)
- øD2:
  - Without finished bore – Without order codes
  - With finished bore – With order codes for diameter and tolerance (product code without **-Z**)

Weights and mass moments of inertia apply to maximum bore diameters.

Maximum speed in rpm  
 $n_{max} = 1146/DB$  DB in m

Other brake disk diameters DB and brake disk widths BB in request.

# FLENDER Standard Couplings

## Flexible Couplings - N-EUPEX and N-EUPEX DS Series

Type EBD with brake disk

### Selection and ordering data

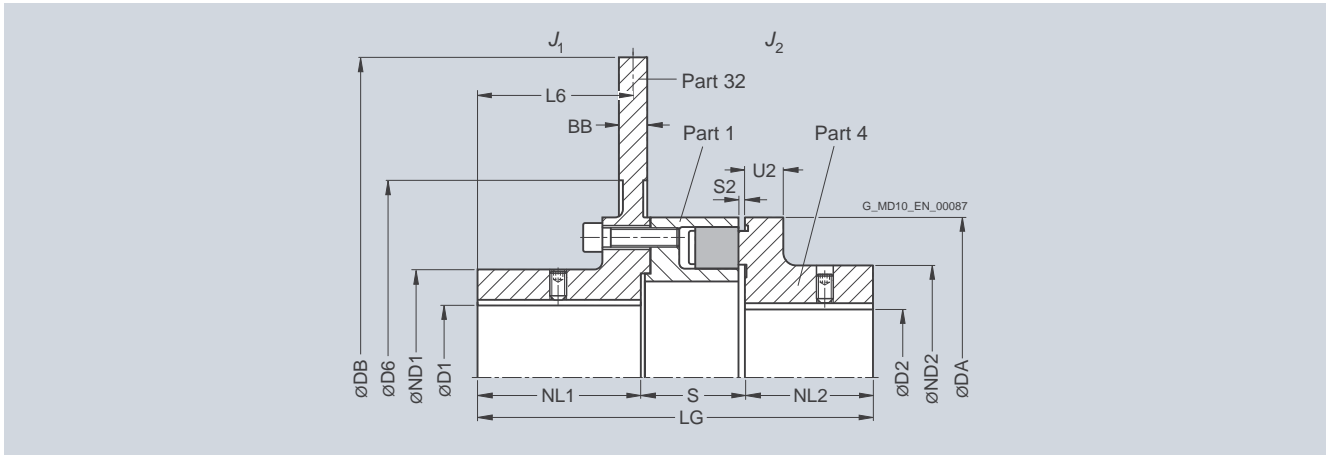

For dimension U2, see type B

Size	Rated torque flexible type 80 ShoreA $T_{KN}$ Nm	Dimensions in mm														Mass moment of inertia		Product code Plain text specification <b>DB</b> ; <b>BB</b> ; <b>D6</b> ; <b>NL1</b> required for order code <b>P0Y</b> Order codes for bore diameters and tolerances are specified in catalog section 3	Weight $m$ min. kg							
		Bore with keyway to DIN 6885			DA		ND1 ND2		NL1 NL2		S S2		DB D6		BB L6		LG $J_1$ $J_2$									
		D1 max.	D2 min.	DA max.	ND1	ND2	NL1	NL2	S	S2	DB min.	D6 min.	BB	L6	LG	$J_1$ min.	$J_2$ min.									
140	360	55	60	140	85	100	81.5	55	49.5	3	315	175	12.7	74	186	0.10	0.007	2LC0100-6AW ■ ■ -OZA0 P0Y	15							
							211.5																16			
																									26	
160	560	70	65	160	105	108	98.5	60	54.5	4	315	175	12.7	91	213	0.11	0.01	2LC0100-7AW ■ ■ -OZA0 P0Y	18							
							211.5																		19	
																									30	
180	880	80	75	180	125	125	98.5	70	56.5	4	355	200	12.7	91	225	0.33	0.02	2LC0100-8AW ■ ■ -OZA0 P0Y	24							
							211.5																			25.5
																										40
200	1340	90	85	200	135	140	104.5	80	62.5	4	400	220	12.7	97	247	0.30	0.04	2LC0101-0AW ■ ■ -OZA0 P0Y	32.5							
							211.5																			34
																										51
225	2000	105	90	225	160	150	111.5	90	66.5	4	450	250	12.7	103	268	0.48	0.07	2LC0101-1AW ■ ■ -OZA0 P0Y	43							
							211.5																			45
																										66
250	2800	110	46	100	250	170	116.5	100	78.5	6	500	280	12.7	107	295	1.5	0.12	2LC0101-2AW ■ ■ -OZA0 P0Y	56							
							211.5																			58
																										83
280	3900	130	54	110	280	200	131.5	110	82.5	6	560	310	12.7	122	324	1.2	0.18	2LC0101-3AW ■ ■ -OZA0 P0Y	73							
							211.5																			76
																										107

- ØD1:
  - Without finished bore – Without order codes
  - With finished bore – With order codes for diameter and tolerance (product code without -Z)
- ØD2:
  - Without finished bore – Without order codes
  - With finished bore – With order codes for diameter and tolerance (product code without -Z)

Weights and mass moments of inertia apply to maximum bore diameters.

**Ordering example:**  
 N-EUPEX EBD coupling, size 200,  
 brake disk DIN 15432-AM-400 mm x 30 mm,  
 Bore D1 55H7 mm, with keyway to DIN 6885 P9 and set screw,  
 Bore D2 60H7 mm, with keyway to DIN 6885 and set screw.  
 Coupling micro-balanced G6.3 at 1500 rpm in accordance with the half parallel key standard.

Product code:  
**2LC0101-0AW99-0ZA0-Z**  
**L1D+M1E+P0Y+W02**  
 plain text to P0Y:  
**DB = 400 mm; BB = 30 mm; D6 = 220 mm; NL1 = 211.5 mm**

The product code applies to standard flexibles of 80 ShoreA; the product code for alternative flexible types is available on request.

Other brake disk diameters DB and brake disk widths BB on request.

Maximum speed in rpm  
 $n_{max} = 1146/DB$  DB in m

# FLENDER Standard Couplings

## Flexible Couplings - N-EUPEX and N-EUPEX DS Series

**Type ADS**  
for easy elastomer flexible replacement

**Selection and ordering data**

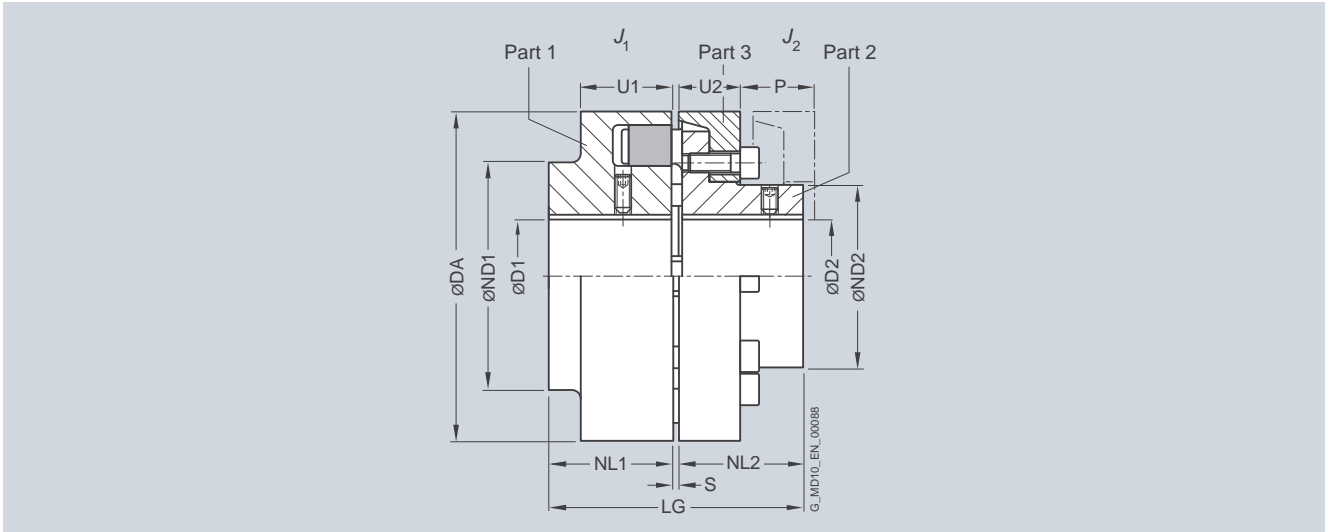

Size	Rated torque $T_{KN}$ Nm	Speed $n_{Kmax}$ rpm	Dimensions in mm											Mass moment of inertia $J_1/J_2$ kgm <sup>2</sup>	Product code Order codes for bore diameters and tolerances are specified in catalog section 3	Weight $m$ kg		
			Bore with keyway to DIN 6885		D1 min.	D2 max.	DA	ND1	ND2	NL1/NL2	S	U1	U2				P	LG
118	160	5300	48	38										118	86	62		
135	240	5100	55	45	135	100	75	50	3	36	23	38	103	0.006	2LC0110-5AB ■ ■ -0AA0	5.5		
152	360	4900	60	50	152	108	82	55	3	36	28	43	113	0.011	2LC0110-6AB ■ ■ -0AA0	7.7		
172	560	4250	65	58	172	118	95	60	4	41	28	47	124	0.019	2LC0110-7AB ■ ■ -0AA0	10.5		
194	880	3800	75	65	194	135	108	70	4	44	30	50	144	0.036	2LC0110-8AB ■ ■ -0AA0	15		
218	1340	3400	85	75	218	150	122	80	4	47	32	53	164	0.062	2LC0111-0AB ■ ■ -0AA0	21		
245	2000	3000	90	85	245	150	138	90	4	52	38	61	184	0.10	2LC0111-1AB ■ ■ -0AA0	28		
272	2800	2750	46	100	95	272	165	155	100	5	60	42	69	0.18	2LC0111-2AB ■ ■ -0AA0	40		
305	3900	2450	49	110	54	105	305	180	172	110	5	65	42	73	0.28	2LC0111-3AB ■ ■ -0AA0	50	
340	5500	2150	49	120	46	100	340	200	165	125	5	70	47	78	255	0.45	2LC0111-4AB ■ ■ -0AA0	72
					90	120	200	200	0.50	73								
380	7700	2000	61	140	61	110	380	230	180	140	5	74	51	83	285	0.75	2LC0111-5AB ■ ■ -0AA0	100
					90	140	230	230	0.80	104								
430	10300	1700	66	150	66	120	430	250	200	160	5	78	56	88	325	1.2	2LC0111-6AB ■ ■ -0AA0	135
					100	150	250	250	1.4	140								
472	13500	1550	80	160	80	130	472	265	215	180	8	86	64	99	368	2.0	2LC0111-7AB ■ ■ -0AA0	174
					120	160	265	265	2.1	180								
514	16600	1400	90	180	90	145	514	300	240	190	8	90	65	104	388	2.9	2LC0111-8AB ■ ■ -0AA0	220
					136	180	300	300	3.2	237								
556	21200	1300	100	190	100	150	556	315	250	210	8	102	68	115	428	4.3	2LC0112-0AB ■ ■ -0AA0	281
					140	190	315	315	4.7	290								

- ØD1:
  - Without finished bore – Without order codes
  - With finished bore – With order codes for diameter and tolerance (product code without -Z)
- ØD2:
  - Without finished bore – Without order codes
  - Without finished bore from size 340 for 2nd diameter range D2 – Without order codes
  - With finished bore – With order codes for diameter and tolerance (product code without -Z)

The hub diameter of the component part is assigned according to the diameter of the finished bore. Where bore diameters overlap, the component with the smaller hub diameter is always selected.

Weights and mass moments of inertia apply to maximum bore diameters.

**Ordering example:**  
N-EUPEX ADS coupling, size 135,  
Part 1: Bore D1 42H7 mm, keyway to DIN 6885 and set screw,  
Part 2: Bore D2 32H7 mm, keyway to DIN 6885 and set screw.

Product code:  
**2LC0110-5AB99-0AA0**  
**LOX+MOT**

The product code applies to NBR standard flexibles; the product code for alternative flexible type is available on request.

# FLENDER Standard Couplings

## Flexible Couplings - N-EUPEX and N-EUPEX DS Series

Type BDS

### Selection and ordering data

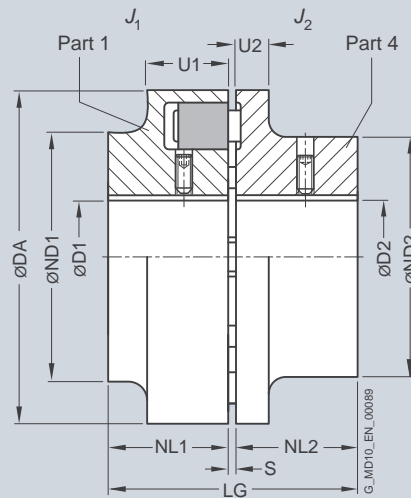

Size	Rated torque $T_{KN}$ Nm	Speed $n_{Kmax}$ rpm	Dimensions in mm										Mass moment of inertia $J_1/J_2$ kgm <sup>2</sup>	Product code Order codes for bore diameters and tolerances are specified in catalog section 3	Weight $m$ kg		
			Bore with keyway to DIN 6885		DA	ND1	ND2	NL1/ NL2	S	U1	U2	LG					
D1	D2	min.	max.	min.									max.				
66	19	7500	19	24	66	66	40	20	3	20	8	43	0.0001	2LC0110-0AA ■ ■ -0AA0	0.50		
76	34	7000	24	28	76	76	50	20	3	20	8	43	0.0002	2LC0110-1AA ■ ■ -0AA0	0.65		
88	60	6000	30	38	88	88	68	30	3	30	10	63	0.0006	2LC0110-2AA ■ ■ -0AA0	1.8		
103	100	5500	42	42	103	76	76	35	3	30	12	73	0.0015	2LC0110-3AA ■ ■ -0AA0	3		
118	160	5300	48	48	118	86	86	40	3	34	14	83	0.003	2LC0110-4AA ■ ■ -0AA0	3.7		
135	240	5100	55	55	135	100	100	50	3	36	18	103	0.007	2LC0110-5AA ■ ■ -0AA0	6.1		
152	360	4900	60	60	152	108	100	55	3	36	20	113	0.011	2LC0110-6AA ■ ■ -0AA0	7.0		
172	560	4250	65	65	172	118	108	60	4	41	20	124	0.019	2LC0110-7AA ■ ■ -0AA0	11		
194	880	3800	75	75	194	135	125	70	4	44	20	144	0.035	2LC0110-8AA ■ ■ -0AA0	17		
218	1340	3400	85	85	218	150	140	80	4	47	24	164	0.06	2LC0111-0AA ■ ■ -0AA0	23		
245	2000	3000	90	90	245	150	150	90	4	52	18	184	0.085	2LC0111-1AA ■ ■ -0AA0	27		
272	2800	2750	46	100	46	100	272	165	165	100	5	60	18	205	0.15	2LC0111-2AA ■ ■ -0AA0	36
305	3900	2450	49	110	49	110	305	180	180	110	5	65	20	225	0.25	2LC0111-3AA ■ ■ -0AA0	47
ØD1:		<ul style="list-style-type: none"> <li>Without finished bore – Without order codes</li> <li>With finished bore – With order codes for diameter and tolerance (product code without <b>-Z</b>)</li> </ul>													1	9	
ØD2:		<ul style="list-style-type: none"> <li>Without finished bore – Without order codes</li> <li>With finished bore – With order codes for diameter and tolerance (product code without <b>-Z</b>)</li> </ul>													1	9	

Weights and mass moments of inertia apply to maximum bore diameters.

#### Ordering example:

N-EUPEX BDS coupling, size 103,  
 Part 1: Bore D1 42H7 mm, keyway to DIN 6885 and set screw,  
 Part 4: Bore D2 32H7 mm, keyway to DIN 6885 and set screw.

Product code:

**2LC0110-3AA99-0AA0**  
**LOX+M0T**

The product code applies to NBR standard flexibles; the product code for alternative flexible type is available on request.

7

# FLENDER Standard Couplings

## Flexible Couplings - N-EUPEX and N-EUPEX DS Series

### Type HDS

#### Selection and ordering data

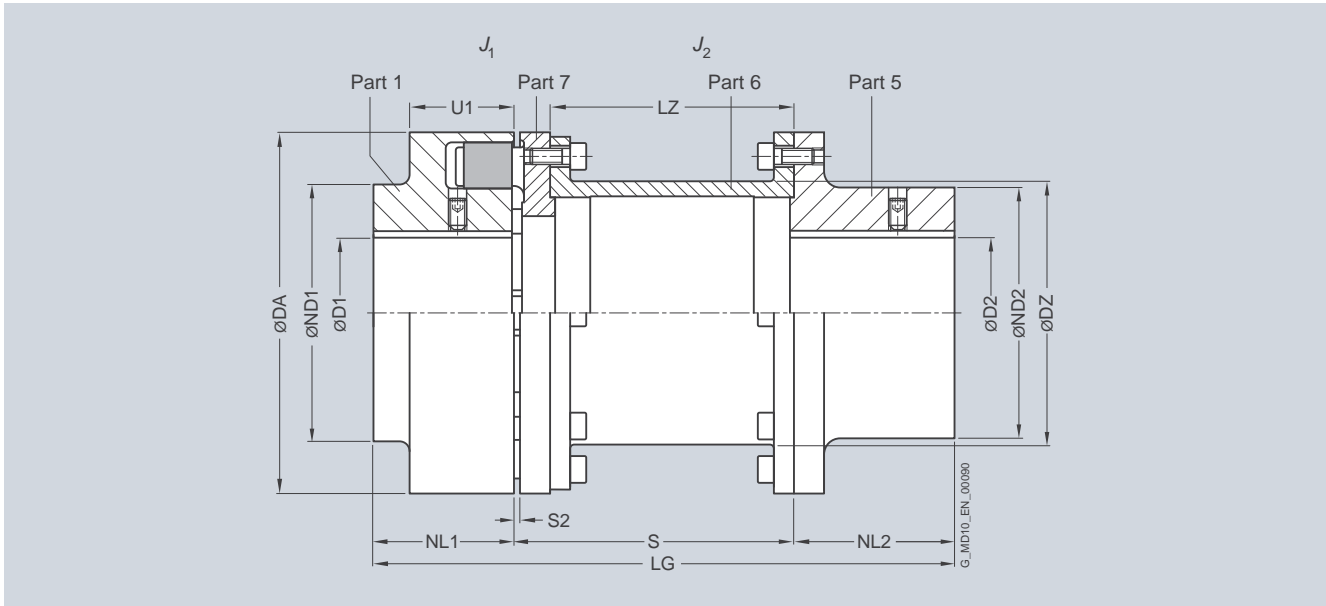

For dimension U1, see type A

Size	Rated torque $T_{KN}$ Nm	Speed $n_{Kmax}$ rpm	Dimensions in mm													Mass moment of inertia		Product code Order codes for bore diameters and tolerances are specified in catalog section 3	Weight $m$ kg
			Bore with keyway to DIN 6885		DA	ND1	ND2	NL1	NL2	S2	S	LZ	DZ	LG	$J_1$	$J_2$			
			D1 min.	D2 max.															
88	60	6000	30	32	88	88	55	30	45	5	100	87	51	175	0.0007	0.0014	2LC0110-2AC	-0AA0	2.8
											140	127	215	0.0015		-0AB0		2.9	
103	100	5500	42	42	103	76	70	35	45	5	180	87	63	180	0.001	0.003	2LC0110-3AC	-0AA0	4.0
											140	127	220	0.0033		-0AB0		4.3	
118	160	5300	48	48	118	86	80	40	50	5	100	85	73	190	0.003	0.006	2LC0110-4AC	-0AA0	5.3
											140	125	230	0.0064		-0AB0		5.7	
											180	165	280	0.0068		-0AC0		6.1	
135	240	5100	55	55	135	100	90	50	5	50	100	85	85	200	0.006	0.01	2LC0110-5AC	-0AA0	7.6
											140	125	240	0.01		-0AB0		8.1	
											180	165	290	0.012		-0AC0		8.6	
											200	185	320	0.012		-0AD0		8.9	
											250	235	380	0.013		-0AE0		9.4	
152	360	4900	60	60	152	108	100	55	65	5	100	82	91	220	0.011	0.02	2LC0110-6AC	-0AA0	11.2
											140	122	260	0.02		-0AB0		11.7	
											180	162	300	0.022		-0AC0		12.2	
											200	182	320	0.023		-0AD0		12.5	
											250	232	385	0.024		-0AE0		13.1	
172	560	4250	65	65	172	118	108	60	70	6	100	81.5	111	230	0.019	0.03	2LC0110-7AC	-0AA0	14.3
											140	121.5	270	0.034		-0AB0		15.0	
											180	161.5	310	0.036		-0AC0		15.9	
											200	181.5	330	0.037		-0AD0		16.2	
											250	231.5	390	0.039		-0AE0		17.2	
194	880	3800	75	75	194	135	125	70	80	6	140	121.5	131	290	0.037	0.058	2LC0110-8AC	-0AB0	21
											180	161.5	330	0.062		-0AC0		22	
											200	181.5	350	0.064		-0AD0		23	
											250	231.5	400	0.069		-0AE0		24	
											140	118.5	144	310		0.062		0.10	2LC0111-0AC
180	158.5	350	0.11	-0AC0	31														
200	178.5	370	0.11	-0AD0	32														
250	228.5	420	0.12	-0AE0	33														

- øD1:
  - Without finished bore – Without order codes
  - With finished bore – With order codes for diameter and tolerance (product code without -Z)
- øD2:
  - Without finished bore – Without order codes
  - With finished bore – With order codes for diameter and tolerance (product code without -Z)



# FLENDER Standard Couplings

## Flexible Couplings - N-EUPEX and N-EUPEX DS Series

Type HDS

Size	Rated torque $T_{KN}$ Nm	Speed $n_{Kmax}$ rpm	Dimensions in mm Bore with keyway to DIN 6885														Mass moment of inertia		Product code Order codes for bore diameters and tolerances are specified in catalog section 3	Weight $m$ kg	
			D1		D2		DA	ND1	ND2	NL1	NL2	S2	S	LZ	DZ	LG	$J_1$	$J_2$			
			min.	max.	min.	max.															
<b>245</b>	2000	3000	90	90	245	150	150	90	100	6	140	118.5	169	330	0.09	0.16	<b>2LC0111-1AC</b> ■ ■ ■ <b>-0AB0</b>	35			
											180	158.5		370			0.17	<b>2LC0111-1AC</b> ■ ■ ■ <b>-0AC0</b>	36		
											200	178.5		390			0.18	<b>2LC0111-1AC</b> ■ ■ ■ <b>-0AD0</b>	37		
											250	228.5		430			0.19	<b>2LC0111-1AC</b> ■ ■ ■ <b>-0AE0</b>	39		
<b>272</b>	2800	2750	46	100	46	100	272	165	165	100	110	8	180	152.5	185	390	0.16	0.3	<b>2LC0111-2AC</b> ■ ■ ■ <b>-0AC0</b>	51	
													200	172.5		410			0.31	<b>2LC0111-2AC</b> ■ ■ ■ <b>-0AD0</b>	52
													250	222.5		460			0.33	<b>2LC0111-2AC</b> ■ ■ ■ <b>-0AE0</b>	55
<b>305</b>	3900	2450	49	110	51	110	305	180	180	110	120	8	250	222.5	215	480	0.28	0.52	<b>2LC0111-3AC</b> ■ ■ ■ <b>-0AE0</b>	74	
<b>340</b>	5500	2150	49	120	51	120	340	200	200	125	140	8	250	222.5	250	515	0.50	0.87	<b>2LC0111-4AC</b> ■ ■ ■ <b>-0AE0</b>	105	
<b>380</b>	7700	1980	61	140	51	140	380	230	230	140	150	8	250	220.5	272	540	0.80	1.4	<b>2LC0111-5AC</b> ■ ■ ■ <b>-0AE0</b>	130	
<b>430</b>	10300	1700	66	150	51	150	430	250	250	160	180	8	250	185.5	310	590	1.4	2.5	<b>2LC0111-6AC</b> ■ ■ ■ <b>-0AE0</b>	205	
<b>472</b>	13500	1550	80	160	51	160	472	265	265	180	180	10	250	182	354	610	2.1	4.1	<b>2LC0111-7AC</b> ■ ■ ■ <b>-0AE0</b>	235	
ØD1:		<ul style="list-style-type: none"> <li>Without finished bore – Without order codes</li> <li>With finished bore – With order codes for diameter and tolerance (product code without <b>-Z</b>)</li> </ul>																1			
ØD2:		<ul style="list-style-type: none"> <li>Without finished bore – Without order codes</li> <li>With finished bore – With order codes for diameter and tolerance (product code without <b>-Z</b>)</li> </ul>																1			
																		9			
																		9			

During assembly, the gap dimension S2 must not exceed the permissible tolerance of +1 mm.

Weights and mass moments of inertia apply to maximum bore diameters.

#### Ordering example:

N-EUPEX HDS coupling, size 103, S3 = 100

Part 1: Bore D1 42H7 mm, keyway to DIN 6885-1 and set screw,

Part 5: Bore D2 32H7 mm, keyway to DIN 6885-1 and set screw.

Coupling micro-balanced G6.3 at 1500 rpm in accordance with the half parallel key standard.

Product code:

**2LC0110-3AC99-0AA0-Z**

**LOX+M0T+W02**

The product code applies to NBR standard flexibles; the product code for alternative flexible type is available on request.

# FLENDER Standard Couplings

## Flexible Couplings - N-EUPEX and N-EUPEX DS Series

### Spare and wear parts

#### Selection and ordering data

##### Elastomer flexibles

The elastomer flexibles are wear parts. The service life depends on the operating conditions.

##### Elastomer flexibles of the N-EUPEX series

Size	Product code flexible set for one coupling NBR elastomer flexibles 80 ShoreA standard type	Number of flexibles per set	Weight per set kg
58	2LC0100-0WA00-0AA0	4	0.012
68	2LC0100-1WA00-0AA0	5	0.015
80	2LC0100-2WA00-0AA0	6	0.02
95	2LC0100-3WA00-0AA0	6	0.03
110	2LC0100-4WA00-0AA0	6	0.045
125	2LC0100-5WA00-0AA0	6	0.06
140	2LC0100-6WA00-0AA0	6	0.09
160	2LC0100-7WA00-0AA0	7	0.12
180	2LC0100-8WA00-0AA0	8	0.17
200	2LC0101-0WA00-0AA0	8	0.23
225	2LC0101-1WA00-0AA0	8	0.3
250	2LC0101-2WA00-0AA0	8	0.38
280	2LC0101-3WA00-0AA0	8	0.55
315	2LC0101-4WA00-0AA0	9	0.7
350	2LC0101-5WA00-0AA0	9	0.85
400	2LC0101-6WA00-0AA0	10	1.2
440	2LC0101-7WA00-0AA0	10	1.5
480	2LC0101-8WA00-0AA0	10	2.1
520	2LC0102-0WA00-0AA0	10	2.6
560	2LC0102-1WA00-0AA0	10	3.6
610	2LC0102-2WA00-0AA0	10	4.9
660	2LC0102-3WA00-0AA0	10	6.3
710	2LC0102-4WA00-0AA0	10	7.6

##### Elastomer flexibles of the N-EUPEX DS series

Size	Product code flexible set for one coupling NBR elastomer flexibles standard type	Number of flexibles per set	Weight per set kg
66	2LC0110-0WA00-0AA0	4	0.012
76	2LC0110-1WA00-0AA0	5	0.015
88	2LC0110-2WA00-0AA0	6	0.021
103	2LC0110-3WA00-0AA0	6	0.033
118	2LC0110-4WA00-0AA0	6	0.048
135	2LC0110-5WA00-0AA0	6	0.072
152	2LC0110-6WA00-0AA0	6	0.1
172	2LC0110-7WA00-0AA0	7	0.16
194	2LC0110-8WA00-0AA0	8	0.21
218	2LC0111-0WA00-0AA0	8	0.28
245	2LC0111-1WA00-0AA0	8	0.45
272	2LC0111-2WA00-0AA0	8	0.64
305	2LC0111-3WA00-0AA0	8	0.72
340	2LC0111-4WA00-0AA0	9	0.92
380	2LC0111-5WA00-0AA0	9	1.2
430	2LC0111-6WA00-0AA0	10	1.6
472	2LC0111-7WA00-0AA0	10	2.0
514	2LC0111-8WA00-0AA0	10	2.5
556	2LC0112-0WA00-0AA0	10	3.2

Flexibles of sizes 66 to 272 are of the compound type with a hard core and soft thrust pieces. Sizes 305 to 556 are completely made of 90 ShoreA NBR material.