

Vibration & Shock

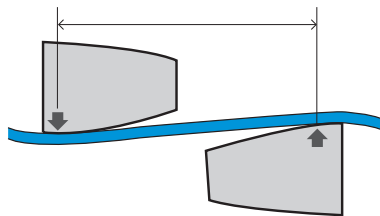

Light Load

The grid contacts near the outer edges of the hub teeth. A long span between the points of contact remains free to flex under load.

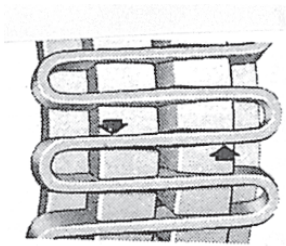
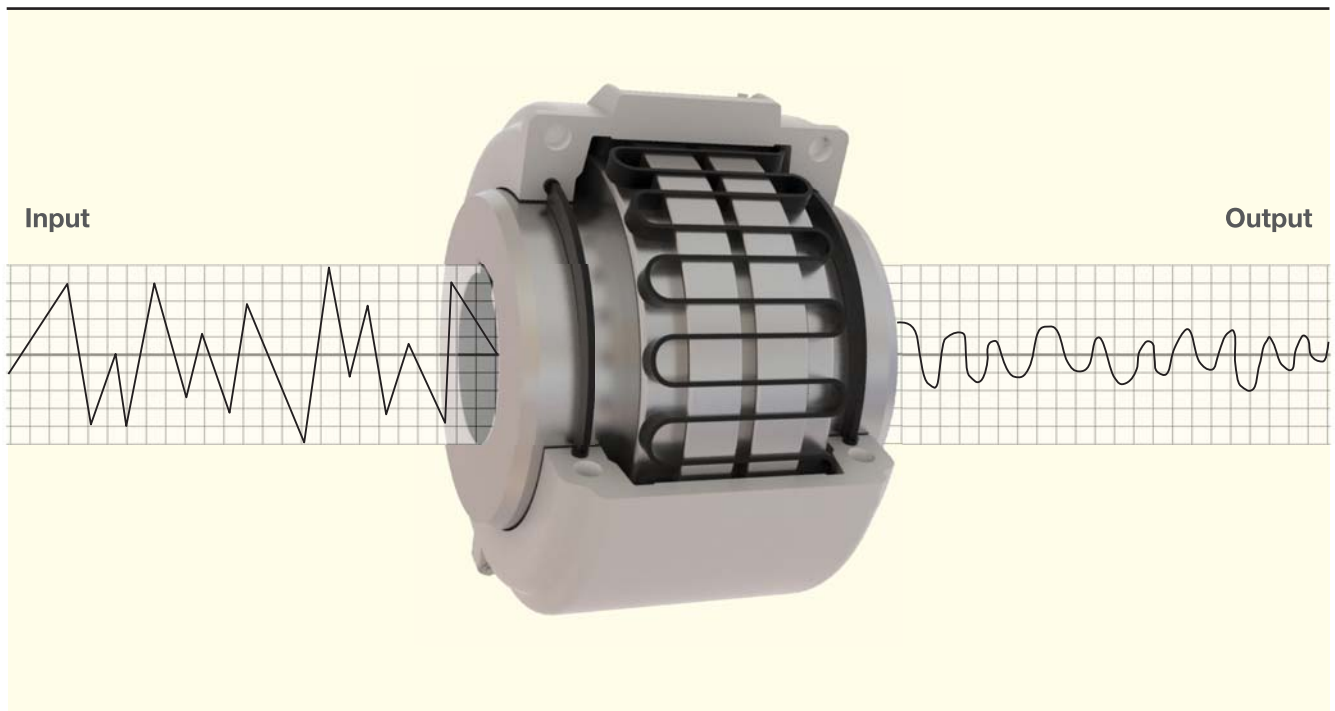
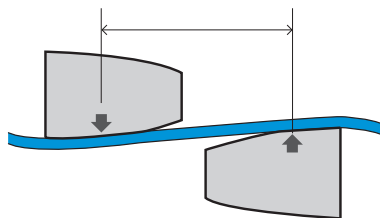
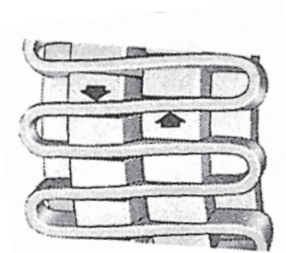

Normal Load

As the load increases, the distance between the contact points on the hub teeth is shortened, but a free span still remains to cushion the load.

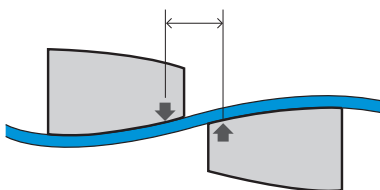
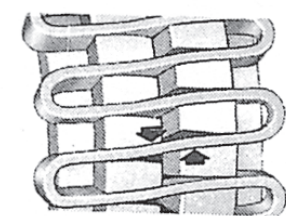

Shock Load

The coupling is flexible within its rated capacity. Under extreme overloads, the grid bears fully on the hub teeth and transmits full load directly.

T10 Type

Close Coupled Horizontal Split Aluminium Cover

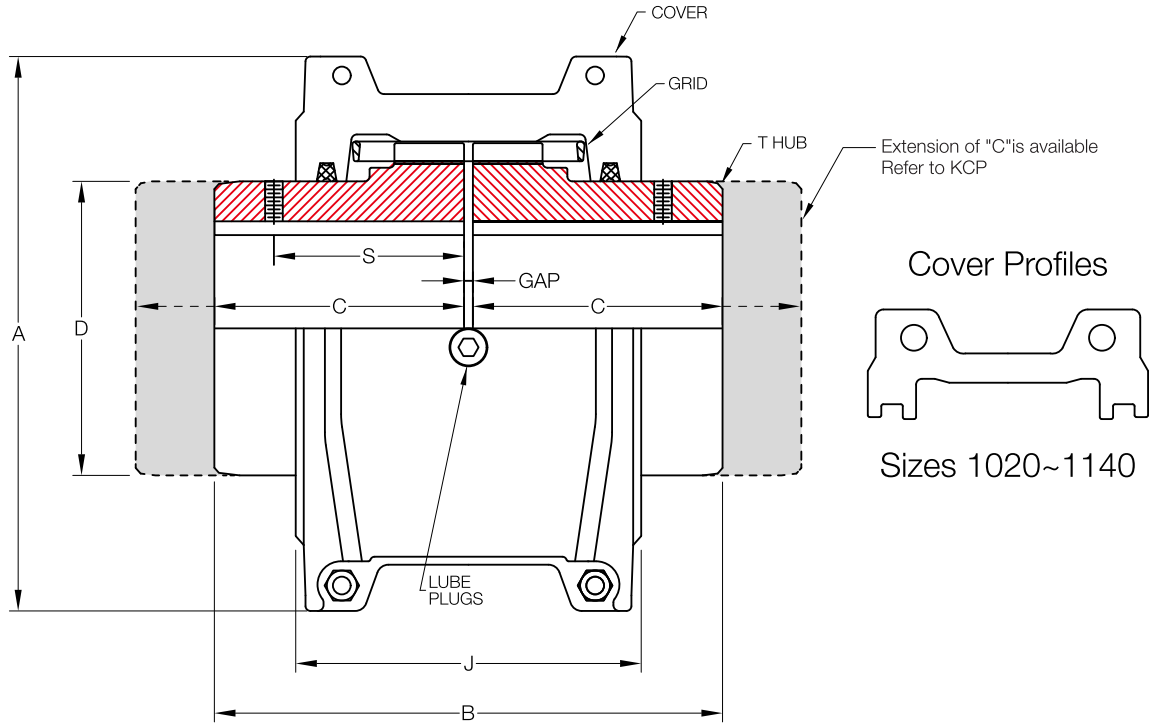

Size	Torque Rating (Nm)	Allow Speed RPM	Max Bore (mm)	Min Bore (mm)	Cplg Weight (Kg)	Lube Weight (Kg)	Dimensions (Millimeters)						Size	
							A	B	C	D	J	S		GAP
1020	52	4,500	28	13	1.92	0.0272	101.0	98.2	47.6	39.7	67.8	39.1	3	1020
1030	149	4,500	35	13	2.58	0.0408	109.0	98.2	47.6	49.2	71.9	39.1	3	1030
1040	249	4,500	43	13	3.34	0.0544	116.0	104.6	50.8	57.2	72.0	40.1	3	1040
1050	435	4,500	50	13	5.44	0.0680	137.8	123.6	60.3	66.7	81.6	44.7	3	1050
1060	684	4,350	56	20	7.44	0.0862	147.0	130.0	63.5	76.2	97.9	52.3	3	1060
1070	994	4,125	67	20	10.40	0.113	162.2	155.4	76.2	87.3	99.2	53.8	3	1070
1080	2,050	3,600	80	27	17.90	0.172	193.0	180.8	88.9	104.8	118.4	64.5	3	1080
1090	3,730	3,600	95	27	25.60	0.254	212.0	199.8	98.4	123.8	127.4	71.6	3	1090
1100	6,280	2,440	110	42	42.00	0.426	250.7	246.2	120.6	142.1	156.6	-	5	1100
1110	9,320	2,250	120	42	54.30	0.508	270.0	259.0	127.0	160.3	162.6	-	5	1110
1120	13,700	2,025	140	61	81.20	0.735	306.4	304.4	149.2	179.4	191.7	-	6	1120
1130	19,900	1,800	170	67	121.00	0.907	343.8	329.8	161.9	217.5	195.5	-	6	1130
1140	28,600	1,650	200	67	178.00	1.130	383.8	374.4	184.2	254.0	201.7	-	6	1140

* Coupling Weight is without Bore Machining

T10 Type (Large)

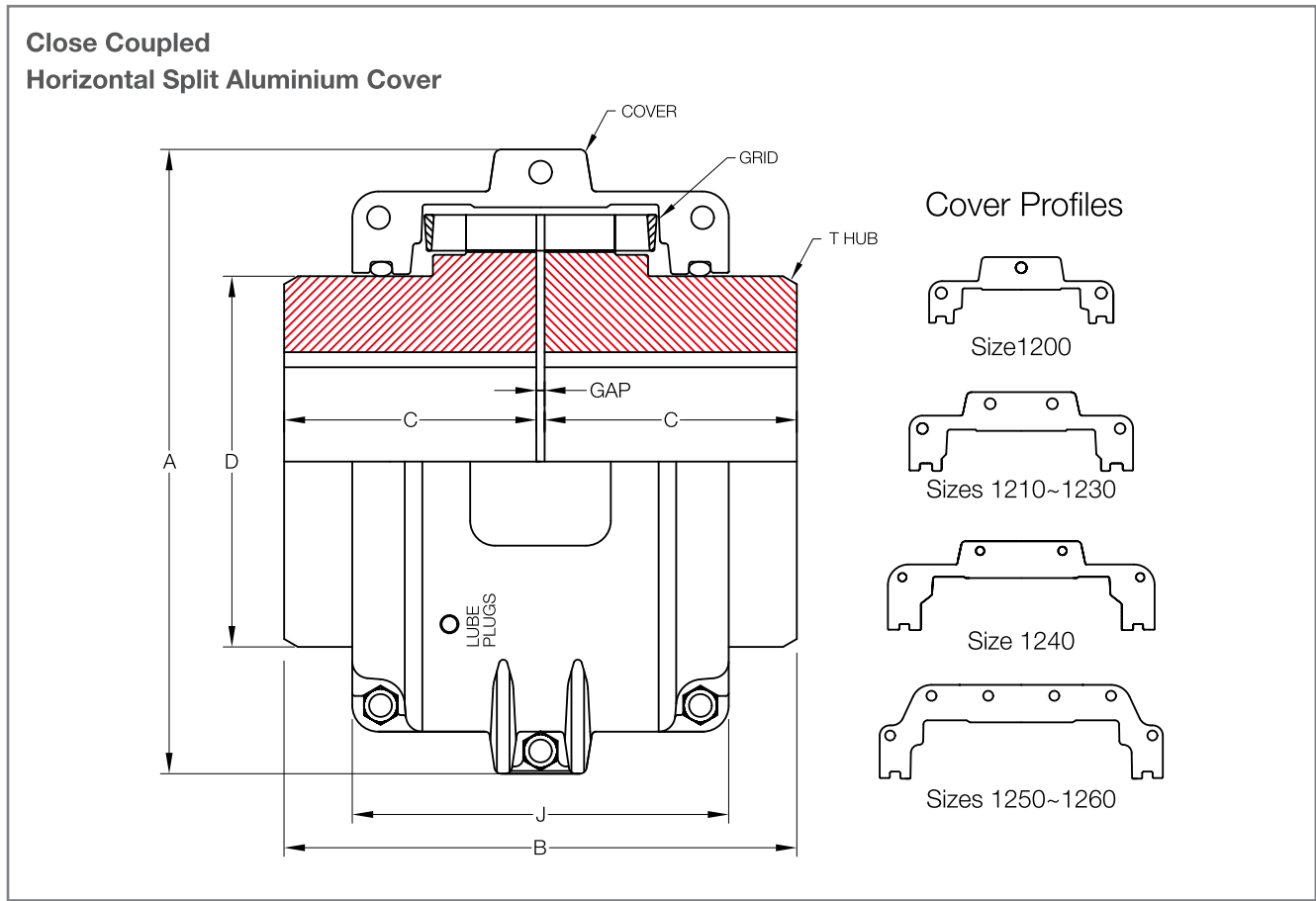

Size	Torque Rating (Nm)	Allow Speed RPM	Max Bore (mm)	Min Bore (mm)	Cplg Weight (Kg)	Lube Weight (Kg)	Dimensions (Millimeters)						Size
							A	B	C	D	J	GAP	
1150	39,800	1,500	215	108	234	1.95	453.1	371.8	182.9	269.2	271.5	6	1150
1160	55,900	1,350	240	121	317	2.81	501.9	402.2	198.1	304.8	278.4	6	1160
1170	74,600	1,225	280	134	448	3.49	566.9	437.8	215.9	355.6	307.3	6	1170
1180	103,000	1,100	300	153	619	3.76	629.9	483.6	238.8	393.7	321.1	6	1180
1190	137,000	1,050	335	153	776	4.40	675.6	524.2	259.1	436.9	325.1	6	1190
1200	186,000	900	360	178	1058	5.62	756.9	564.8	279.4	497.8	355.6	6	1200
1210	249,000	820	390	178	1424	10.50	844.6	622.6	304.8	533.4	431.8	13	1210
1220	336,000	730	420	203	1785	16.10	920.8	663.2	325.1	571.5	490.2	13	1220
1230	435,000	680	450	203	2267	24.00	1,003.3	703.8	345.4	609.6	546.1	13	1230
1240	559,000	630	480	254	2950	33.80	1,087.1	749.6	368.3	647.7	647.7	13	1240
1250	746,000	580	-	254	3833	50.10	1,181.1	815.6	401.3	711.2	698.5	13	1250
1260	932,000	540	-	254	4682	67.20	1,260.9	876.6	431.8	762.0	762.0	13	1260

* Coupling Weight is without Bore Machining

T20 Type

Close Coupled Vertical Split Steel Cover

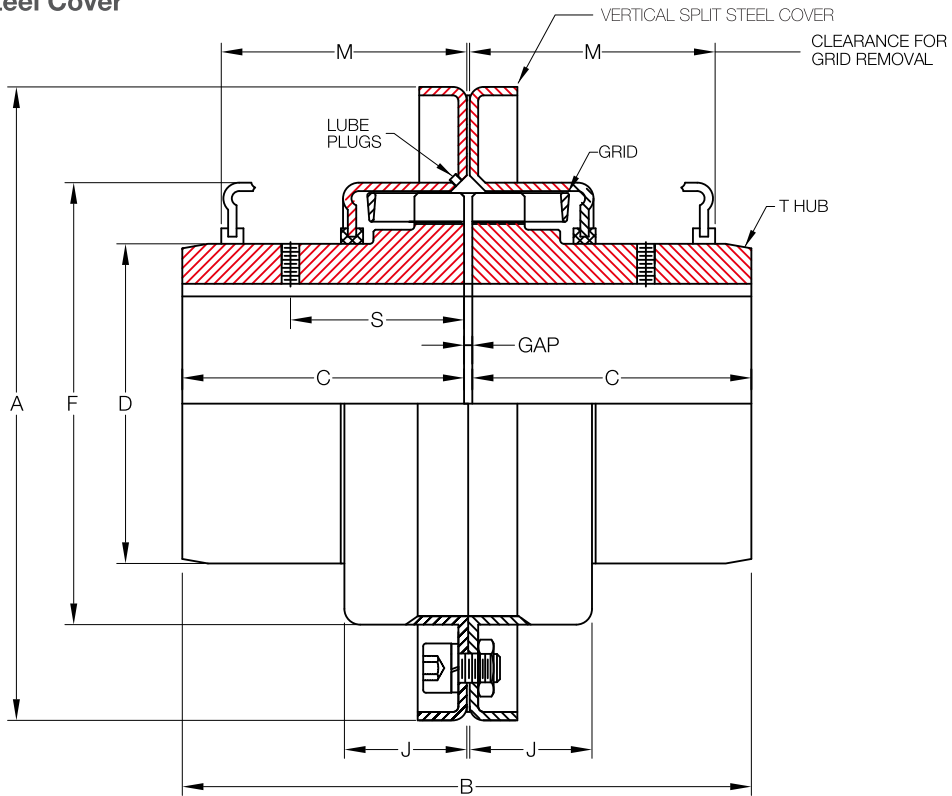

Size	Torque Rating (Nm)	Allow Speed RPM	Max Bore (mm)	Min Bore (mm)	Cplg Weight (Kg)	Lube Weight (Kg)	Dimensions (Millimeters)								Size
							A	B	C	D	F	J	M	GAP	
1020	52	6,000	28	13	1.94	0.0272	112.3	98.2	47.6	39.7	64.3	23.9	47.8	3	1020
1030	149	6,000	35	13	2.58	0.0408	121.8	98.2	47.6	49.2	73.8	24.9	47.8	3	1030
1040	249	6,000	43	13	3.35	0.0544	129.8	104.6	50.8	57.2	81.8	25.9	50.8	3	1040
1050	435	6,000	50	13	5.32	0.0680	148.8	123.6	60.3	66.7	97.6	30.5	60.5	3	1050
1060	684	6,000	56	20	7.01	0.0862	163.1	130.0	63.5	76.2	111.1	31.8	63.5	3	1060
1070	994	5,500	67	20	10.20	0.1130	174.2	155.4	76.2	87.3	122.3	33.5	66.5	3	1070
1080	2,050	4,750	80	27	17.60	0.1720	201.2	180.8	88.9	104.8	149.2	43.7	88.9	3	1080
1090	3,730	4,000	95	27	25.40	0.2540	232.9	199.8	98.4	123.8	168.3	47.0	95.2	3	1090
1100	6,280	3,600	110	42	42.00	0.4260	267.9	246.2	120.6	142.1	198.0	59.7	120.7	5	1100
1110	9,320	3,000	120	42	54.40	0.5080	286.9	259.0	127.0	160.3	216.3	62.7	124.0	5	1110
1120	13,700	2,700	140	61	81.80	0.7350	320.2	304.4	149.2	179.4	245.5	73.7	142.7	6	1120
1130	19,900	2,400	170	67	122.00	0.9070	379.0	329.8	161.9	217.5	283.8	74.9	146.0	6	1130
1140	28,600	2,200	200	67	180.00	1.1300	417.1	374.4	184.2	254.0	321.9	78.2	155.4	6	1140
1150	39,800	2,000	215	108	230.00	1.9500	476.2	371.8	182.9	269.2	374.4	107.3	203.2	6	1150
1160	55,900	1,750	240	121	321.00	2.8100	533.4	402.2	198.1	304.8	423.9	115.3	215.9	6	1160
1170	74,600	1,600	280	134	448.00	3.4900	584.2	437.8	215.9	355.6	474.7	120.1	226.1	6	1170
1180	103,000	1,400	300	153	591.00	3.7600	630.0	483.6	238.8	393.7	546.0	130.0	-	6	1180
1190	137,000	1,300	335	153	761.00	4.4000	685.0	524.2	259.1	436.9	589.0	135.0	-	6	1190
1200	186,000	1,100	360	178	1021.00	5.6200	737.0	564.8	279.4	497.8	652.0	145.0	-	6	1200

* Coupling Weight is without Bore Machining